

# THE EYE

# IN HISTORY

A compilation of articles on Instruments, Books and Individuals that shaped the course of Ophthalmology

## Mr. Richard KEELER

FRCOphth (Honorary)

## Professor Harminder S DUA

Chair and Professor of Ophthalmology, University of Nottingham

MBBS, DO, DO (London), MS, MNAMS, FRCS (Edinburgh), FEBO, FRCOphth,

FRCP (Honorary, Edinburgh), FCOptom. (Honorary), FRCOphth. (Honorary), MD, PhD.

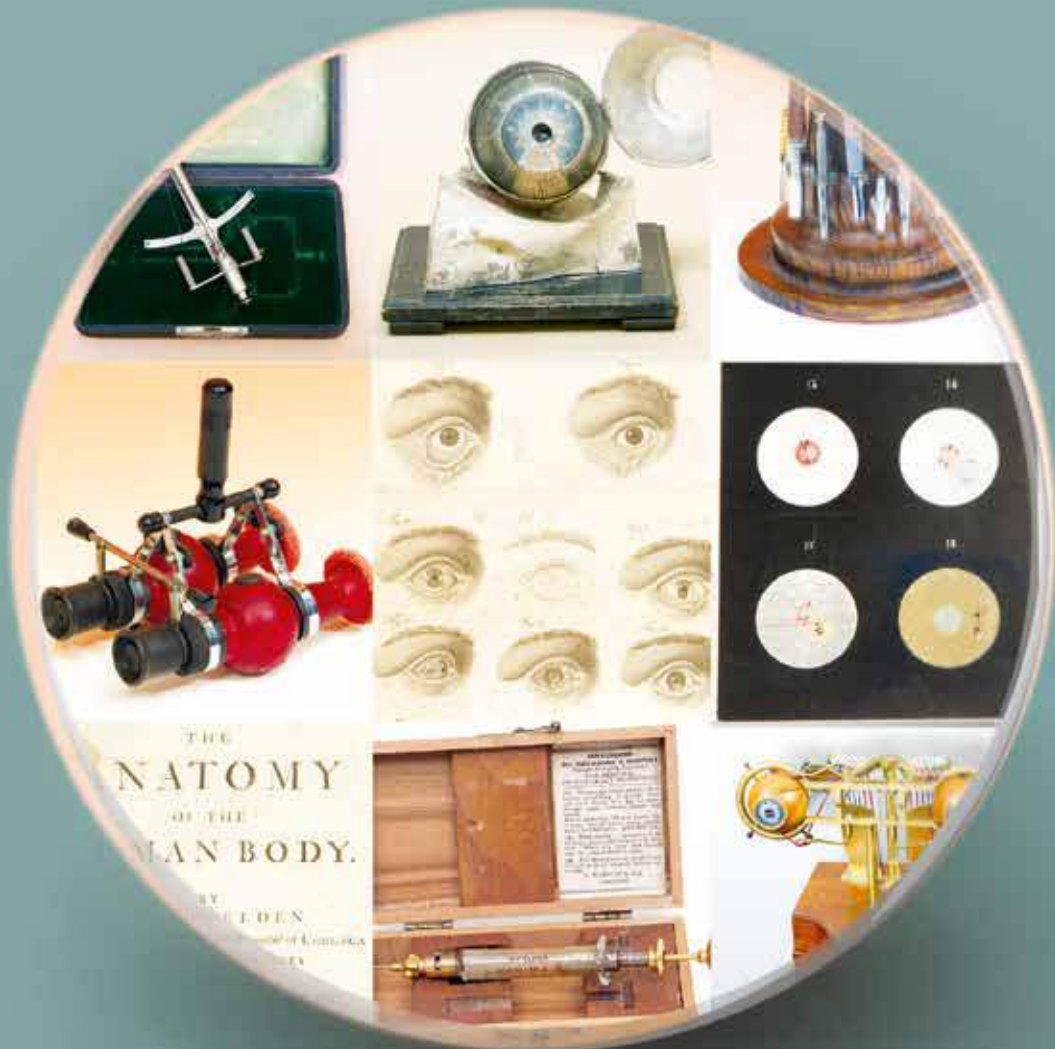



## EDITION

Edited by:

Laboratoires Théa

12 Rue Louis Blériot - ZI du Brézet

63017 Clermont-Ferrand cedex 2 - France

Tel. +33 (0)4 73 98 14 36 - Fax +33 (0)4 73 98 14 38

[www.laboratoires-thea.com](http://www.laboratoires-thea.com)

The content of the book presents the viewpoint of the authors and does not necessarily reflect the opinions of Laboratoires Théa.

Mr. Richard KEELER and Prof. Harminder S DUA have no financial interest in this book.

All rights of translation, adaptation and reproduction by any means are reserved for all countries.

Any reproduction, in whole or part, by any means whatsoever, of the pages published in this book, is prohibited and unlawful and constitutes forgery without the prior written consent of the publisher. The only reproductions allowed are, on the one hand, those strictly reserved for private use and not intended for collective use and, on the other hand, short analyses and quotations justified by the scientific or informational nature of the work into which they are incorporated.

(Law of 11 March 1957, art. 40 and 41, and Penal Code art. 425)



## PREFACE

For seven years (2007-2014) Dr. Arun D Singh and I served as editors-in-chief of the British Journal of Ophthalmology (BJO), published by the BMJ publishing group. Even before we were formally appointed to the post we had discussed the cover image and its concept. A cover image should serve to attract the attention of the 'passer-by', to arouse curiosity sufficient to make him or her reach out to pick up the journal and find the answer to the question that fleets across the mind, what is that on the cover? The answer is tactically hidden in the content of the journal requiring the individual to flip through the pages. The expectation being that an article or two might also attract attention and be read. We decided to depict images from the 'eye in history' and the 'eye in mythology' on alternate months.

For the former, it did not take us long to discover a gold mine of material and a golden mind of information in Richard Keeler, who was then and still is, the honorary curator of the museum, which includes the antique instruments and the antiquarian library, of the Royal College of Ophthalmologists, UK (see Richard's biography on page 10). For seven years, with unfailing regularity, Richard provided material and information to adorn the cover of the BJO. On conclusion of my term in office, Richard and I decided to compile and enhance the cover images and related text into a book, for posterity. Though always available through online archives, the material will be lost in bound volumes of hard copies stored in libraries, where the covers are usually not included.

This book however, is not merely a representation of old material in a different format. Modern curricula for ophthalmic qualifications tend to place little emphasis on history. They ignore the quotes "ignore history at your peril" and "Those who do not learn history are doomed to repeat it" (George Santayana, philosopher). Most of the things we take for granted today, did not just happen. They followed a course of trials and tribulations and modifications and improvements in small increments. The history of each instrument and treatment illustrates that "Success is the culmination of failures", a lesson that applies not only to the devices depicted but also to Life in general. A message that every student should keep in mind while treading their professional path. Failure is only a corner; around which Success could be waiting.

The advent of the direct ophthalmoscope is regarded as the starting point of modern ophthalmology. Today it is used far less often, being superseded by sophisticated imaging modalities. Such is the pace of change, that a new device, medicine or surgery will be introduced, used and rendered obsolete several times in a professional lifetime. We are creating history and living through history while we march in to the future. "Today is the yesterday of tomorrow", "What is today state of the art will tomorrow be relegated to the dustbin of history" (HS Dua). Equally, advances in knowledge and understanding can resurrect ideas and principles from History that were far ahead of their times.

This book will put in perspective the thoughts expounded above and empower the reader to better deal with the future while providing some knowledge on what used to be.

*Harinder S DUA*



**Mr. Richard KEELER**

It was when I retired that I became fascinated in the history of ophthalmology from both an instrument and literature standpoint. The turning point was when I was invited to become Honorary Curator at the College of Ophthalmologists in 1997.

Since then I have built up, through gifts and purchases, a large collection of instruments and antiquarian books that feature in this book.

My whole life has been spent in the world of optics and ophthalmic instruments. From the start I have been imbued with a love of optics, anatomy of the eye and ophthalmological instruments.

One can say that the Keeler ophthalmic instruments business really started in 1906 when my grandfather Charles Davis Keeler, at the age of 30, arrived with his family in England from Philadelphia. This was very much against the flow of migration but he had a purpose. He was to establish, as the manager, a branch in London of the Standard Optical Co of Geneva, NY which manufactured machinery for making lenses and spectacle frames.

This move proved successful but his career took a different course in 1910 when he went into partnership with John Reiner to set up a Dispensing Optician practice, Reiner (later Rayner) and Keeler Ltd, in the West End of London. The partnership lasted until 1916 when my grandfather broke away and opened his first Dispensing Optician establishment nearby the following year in 1917.

I was born in 1937 at Windsor, twenty five miles from London, in a large house surrounded by paddocks, stables and an indoor riding school that my father had bought a few years before.

Very soon this property was to prove a fortuitous purchase when the Second World War broke out in 1939. The manufacture of spectacles, lenses and instruments then in London was hastily moved from there into converted stables and the indoor riding school.

Today the Keeler Group now owned by Halma Ltd, a FTSE quoted company, still operates from a modern factory within the grounds of this property.

The articles in this book cover a wide variety of subjects. A theme that runs through the History of the Eye is that experimentation, research, invention, risk-taking and sometimes luck moved the profession forward sometimes quite slowly and at other times in great leaps. Those that are ignorant of the rich history of the evolution of ophthalmology are missing out on the fascinating and timely discoveries that make up the profession today. They would find it very advantageous to study ophthalmic history so that they can learn from the successes and failures of the past.

For me re-reading the account of the discovery by the young Professor Hermann von Helmholtz in 1850 of how to view the fundus of the eye still makes my heart beat a little faster. The design and manufacture of ophthalmoscopes was an important part of my working life and now the collecting of old ophthalmoscopes, other instruments and books has taken over my waking hours resulting in one of the most comprehensive collections in the world which is on display at The Royal College of Ophthalmologists.

*Richard KEELER*



**Professor Harminder S DUA**

My father Inder Singh Dua, retired as an Air Commodore in the Indian Air Force. My mum, Kulwant Kaur, was a specialist in food preservation. My siblings and I followed our dad through his transfers to different bases. I must have changed seven schools before joining the Government Medical College and Hospital in Nagpur, India. After MBBS I specialized in Ophthalmology with a Diploma (DO) and Masters (MS) degree; and pursued basic research in uveitis for a PhD, whilst being employed as a Lecturer and then Reader in Ophthalmology. I married Rita, who was specializing in anaesthesia and spent a memorable year in Pune (Poona) before deciding to quit government service and pursue a career abroad.

I arrived in the UK on a cold winter night in December 1983 to take the professional and linguistics assessment board examination of the General Medical Council. My first placement was as an observer in York and my first paid job was as a locum in St Helens, which lasted a couple of weeks before joining Huddersfield as senior house officer with Mr Jawaharlal Agarwal and Mr Murphy. The education and training that I had received in India provided a solid foundation on which I built my career with the numerous positives that the British system had to offer. From Huddersfield I moved to Aberdeen in December 1984 to work under the supervision of Professor John Forrester and also obtained an MD from the Aberdeen University. I completed my training as I moved from Registrar to Senior Registrar and then took an opportunity that presented, to spend time with Professors Larry A. Donoso and Peter Laibson, at the Wills Eye Hospital, Philadelphia. A year as Research Fellow with Larry and a year with Peter as a Cornea Fellow rounded off my rather protracted training in Ophthalmology. I was accorded the title of Associate professor at the Thomas Jefferson University. My career felt like a game of 'snakes and ladders'; from a Reader in Pune to SHO in Huddersfield to Senior Registrar in Aberdeen to Fellow in Philadelphia, each time I reached the top row a 'snake' got me and I had to throw the dice again. I encountered the tallest 'ladder' when I was invited to the Chair of Ophthalmology at the University of Nottingham through a long-distance call during lunch hour in the cafeteria of the Wills. I arrived in Nottingham in April 1994 and the rest as they say, is history.

I have had a very fulfilling, rewarding and satisfying career pursuing my professional passions of teaching, research, and service both to patients and my profession. Highlights of these facets of my career have been my term as President of the Royal College of Ophthalmologists and now as Master of the Oxford Ophthalmological Congress; the Times Higher Education Award for 'Research project of the year'; my term as (co) Editor-in-chief of the British Journal of Ophthalmology; the Rotary Foundation global alumni Service to Humanity award and comments such as these "I found guidance, friendship and love, everything in one person and that person is you. You have a special way of making the world a better place, just because you are you. Thanks you for everything." from a student and "I am very grateful to you indeed. It is so good to have a doctor in whom I have trust; that, in itself, is very therapeutic." from a patient.

I was once asked "What is the enduring message you can give to young doctors?" In the twilight of my career I think I have found the answer "Always do what is in the best interest of your patients. They are your best teachers as they will teach you more than any book can. They are your best admirers as they will reward you more than anyone else can. They will think you are God, try and prove them right".

*Harminder Singh DUA*





## ACKNOWLEDGEMENT

If one wishes to know the effort and energy, the time and tasks, the work and worry and more, that it takes to write a book from the conception of an idea to fondling the first printed copy, then one must write a book. The first thing we learnt was that we could do with a lot of help and we were fortunate to get it. As sole author of this acknowledgement, I use my prerogative to start by thanking the first author of this book, Mr Richard Keeler for his immense and valuable contribution. In superlative parlance, in the context of knowledge of the History of Ophthalmology, Richard is nothing short of a National Treasure. Anything he does not know is probably not worth knowing. His wealth of information is complemented by his collection of antique eye instruments and books that he has generously donated to museums of the Royal College of Ophthalmologists, UK and other institutions. The images depicted in this book are from that collection.

Special thanks are due to Arun Singh, co-editor of the British Journal of Ophthalmology, who served a term of seven years with me and co-authored the text related to the cover images published over those years. We used material from Richard's collection and articles on 'the eye in mythology' on alternate months. Clive Burrows was co-author of the article on the 150th anniversary of the binocular indirect ophthalmoscope. His contribution is acknowledged.

All staff of the British Journal of Ophthalmology, BMJ publishing group, who helped us produce a journal every month, especially Mark Thomas who took the photographs for the cover image, are acknowledged with fondness and gratitude.

The Royal College of Ophthalmologists, UK deserves very special appreciation for the generosity in allowing use of the material but also for providing an elegant home for the antiquities and safeguarding them for posterity.

All ophthalmologists in the UK and in many other countries across the globe, especially in Europe are familiar with the products made by Théa, a family owned company based in France, that has raised the bar to new heights when it comes to developing and providing preservative-free and other niche eye medications and supporting education and research in ophthalmology. This book, like many others before it, will be part of the Théa medical library collection and bear testimony to Théa's commitment to education and dissemination of knowledge. It is therefore imperative that mention is made, with heartfelt thanks, to all from Théa who made this happen; Jean-Frédéric Chibret, President of Laboratoires Théa; Henri Chibret, President of Théa Holding; Christine Purslow; Nikolaos Mouzakis; Béatrice Albiol; Catherine Nicolle and Philip Lewis-Williams. Nikolaos was our contact person on the team and kept us on our toes "in sickness and in health"; Béatrice and Catherine worked behind the scene to translate ideas into pages and Jean-Frédéric and Henri provided leadership and inspiration by personally attending to this venture, which in the context of the magnitude of their business, would be a miniscule undertaking.

Finally, to all the individuals, inventors and authors whose work is included in the book, a posthumous "thank you" for your ideas that have endured and enthused generations that followed in your footsteps.

*Harminder Singh DUA*

# TABLE OF CONTENTS

|  |    |
|--|----|
| Preface  |    |
| About the authors by the authors   |    |
| Acknowledgement  |    |
| PERRIN'S PHANTOM EYE: THE ART OF EDUCATION .....   | 17 |
| DOUBLE OPTOMETER: WHEELING IT IN.....  | 18 |
| FOCIMETER: FOCUSING ON POWER .....   | 20 |
| TEACHING OCULAR PATHOLOGY: GLASS TO GLASS JARS .....   | 21 |
| WOOL OVER EYES: HOLMGREN'S SKEINS<br>AND THOMSON'S STICK.....                                      | 22 |
| PRESSURE TO MEASURE PRESSURE:<br>THE MCLEAN TONOMETER .....  | 23 |
| THE STEREOSCOPE: SCOPING THE THIRD DIMENSION.....  | 24 |
| OPHTHALMOTROPES: THE EYE IN MOTION.....  | 26 |
| CARVING THE CORNEA: THE VON HIPPEL TREPHINE.....   | 28 |
| ANATOMICAL EYE MODEL.....  | 29 |
| TRAIL OF TRIAL LENSES .....  | 30 |
| ELECTRIC EYES: WIRTZ IONTOPHORESIS ELECTRODES .....  | 31 |
| CALCULATING CURVES: KERATOMETERS<br>AND OPHTHALMOMETERS .....                                      | 32 |
| REFLECTING ON REFLECTIONS: GULLSTRAND'S LARGE<br>REFLEX-FREE OPHTHALMOSCOPE .....                  | 33 |
| DISC-FULL OF DRUGS: COMPRESSED OPHTHALMIC DISCS.....   | 34 |
| ALL FOR A DROP: UNDINES AND DROP BOTTLES.....  | 36 |
| RECUMBENT SPECTACLES: TAKING IT LYING DOWN .....   | 38 |
| DETECTING DEFECTS: THE MCHARDY PERIMETER.....  | 39 |
| DOUBLING UP: TWO PRISMS, TWO NAMES,<br>TWO COUNTRIES .....   | 40 |
| SMOKY SOLUTION TO PRESSURE PROBLEMS:<br>FICK'S OPHTHALMOTONOMETER.....                             | 42 |
| THE 150 <sup>TH</sup> ANNIVERSARY OF THE BINOCULAR INDIRECT<br>OPHTHALMOSCOPE (1861-2011).....     | 44 |
| RYLAND SCHEMATIC EYE: A SCHEME TO LEARN .....  | 47 |
| EMPOWERING EYES: THE THORNER OPTOMETER.....  | 48 |
| SUCTION EXTRACTION: TAKING A GRIP ON INTRACAPSULAR<br>CATARACT EXTRACTION WITH THE ERYSIPIHAK..... | 50 |

|  |     |
|--|-----|
| CUT IT, BURN IT, LYSE IT: ZIEGLER'S ELECTROLYSIS AND CAUTERY SET .....                         | 52  |
| REDUCING ERRORS IN MEASURING REFRACTIVE ERRORS:<br>DE ZENG REFRACTOMETER .....                 | 54  |
| TESTING VISION CAN BE TESTING: WORTH'S IVORY-BALL TEST .....                                   | 56  |
| THE GREAT AND THE WRONG: DR WILLIAM BRIGGS .....   | 58  |
| GOLDEN EYES .....  | 60  |
| SCOPING STRABISMUS: STAND-MOUNTED SYNOPTISCOPE .....   | 62  |
| THE ART OF SURGERY: SIR WILLIAM ADAMS (1783-1827) .....  | 64  |
| MASSEURS: FOR YOUR EYES ONLY .....   | 66  |
| EYES THROUGH BADER'S EYES: CHARLES BADER (1825-1899) .....                                     | 68  |
| CATARACT SURGERY SPRINGING INTO ACTION:<br>THE FRENCH CONNECTION .....                         | 70  |
| FATHER OF BRITISH OPHTHALMOLOGY, RICHARD BANISTER (1570-1625) .....                            | 72  |
| BATTLING WITH REFLECTIONS: THE BUSCH STEREOSCOPIC<br>REFLEXLESS BINOCULAR OPHTHALMOSCOPE ..... | 74  |
| STANDING UP TO THE OPERATION .....   | 76  |
| A MASTER MASTERING THE OPHTHALMOSCOPE: EDUARD VON JAEGER .....                                 | 78  |
| EYEING THE BEST .....  | 80  |
| LEECHING BLOOD .....   | 82  |
| AUTHORS, BOOKS AND EYES: NOT A FACE FULL OF EYES .....   | 84  |
| SCREENING FOR PRESSURE: THE BERENS TOLMAN TONOMETER .....                                      | 86  |
| BONES AND EYES .....   | 88  |
| CROWN OF TREPHINES FOR THE KING OF CORNEA .....  | 90  |
| OF FATHERS AND SONS: ANTONIO SCARPA (1752-1832) .....  | 92  |
| THE AMBLYSCOPE THAT WAS "WORTH" IT .....   | 94  |
| JOHN VETCH AND HIS TRACHOMA BATTLES .....  | 96  |
| THE INSTRUMENTAL NATHANIEL BISHOP HARMAN (1869-1945) .....                                     | 98  |
| THE SHARPE KNIFE .....   | 100 |
| EYE, MAGNETISM AND MAGNETS .....   | 102 |
| GUILLAUME PELLIER DE QUENGSY: A BOLD EYE SURGEON .....   | 104 |

Edition





Display of artefacts from the Ophthalmological collection at The Royal College of Ophthalmologists, UK.



# PERRIN'S PHANTOM EYE: THE ART OF EDUCATION



Fundus cameras, digital photography, video imaging, interactive DVDs and the like are standard teaching aids available to most ophthalmology residents learning their trade. Visualisation of changes both on and in the eye has never been easier but has not always been so. For approximately 15 years after the invention of the direct ophthalmoscope, many ophthalmologists and students were not entirely sure of what they were looking for when examining the fundus of the eye. The introduction of the artificial or "phantom eye" (fig.1) in 1866 by Maurice Perrin (1826–1889) could be considered as a major advance in ophthalmic education.

A full set of the Perrin's "eye" had twelve brass shells on which various eye conditions were meticulously painted in fine detail. These shells were mounted in the back of a hollow brass globe (fig.2) and

could be viewed with an ophthalmoscope. Three eyepieces, with different pupil apertures of 7 and 3 mm diameters, could be screwed on to the front of the globe giving the possibility of demonstrating the conditions of myopia, hypermetropia and astigmatism.

Perrin received his doctorate in Paris in 1851. In 1871 he was promoted to the position of Medecin-Inspecteur which was the highest rank in the military medical service in the French Army. He was also professor at the Val-de-Grace medical school in Paris. Perrin also published an atlas of fundus conditions in his book "Atlas des maladies profondes de l'oeil comprenant l'ophthalmoscope" in 1879 (fig.3).

Reproduced/adapted from Br J Ophthalmol, Perrin's phantom eye, R. Keeler, A. Singh, H. Dua, 92, 344, Mar 1 2008 with permission from BMJ Publishing Group Ltd.



Fig.1 ▶ The introduction of the artificial or "phantom eye"

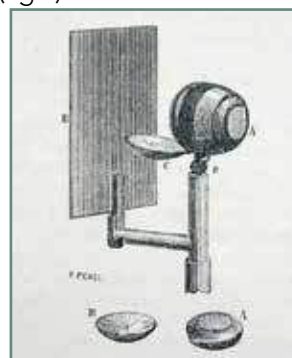

Fig.2 ▶ Hollow brass globe

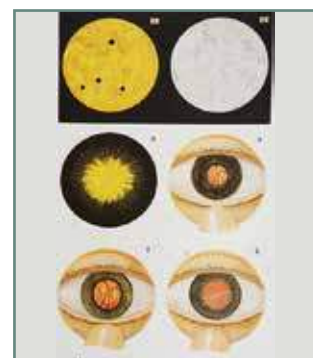

Fig.3 ▶ A page from the atlas

## DOUBLE OPTOMETER: WHEELING IT IN



A refractive error is an inability of the eye to bring objects into proper focus. The eye can be long-sighted when the focusing power is less than it should be, requiring convex or plus lenses; short-sighted, when the power is more than what it should be, requiring concave or minus lenses, or astigmatic, requiring in addition to a plus or minus lens, a cylindrical lens. Attempts to correct refractive errors started hundreds of years ago. Inevitably, instruments were developed to make refraction easier, quicker and more accurate. Today, uncorrected refractive errors remain the commonest cause of visual impairment, the world over.

In early days, when methods for testing for refractive errors did not exist, the public bought their spectacles, mainly for reading (presbyopic correction), from street vendors by self-selection. They tried a few and bought the one that suited them best. The spectacles had the same spherical power in each eye and getting the correct one was hit-or-miss as it may have corrected or nearly corrected only one eye. Not surprisingly this remained a very cheap method of getting reading glasses and is in vogue to this

day. One can walk into any high street drug store, try a few from a rack of different powers and walk out with a pair that seems most suitable!

One of the early instruments for testing the refractive requirements for a patient was the "Box" lens set (see page 32). Several pairs of spectacle frames supporting different powers or combination of powers of lenses, with a handle at their base, could be held before the patient's eyes. This was an improvement but not by much. This method was superseded by the first trial set introduced by Georg Fronmuller of Furst in 1843. The trial set had a wide range of lenses, both plus and minus, in small increments that enabled more accurate assessment of the patient's refractive error but was essentially subjective. The early trial sets did not have any cylindrical lenses, which was a major drawback.

An optometer is an instrument designed for testing the refractive error of the eye. The instrument was christened 'optometer' by a Scottish physician, William Porterfield (1695-1771) over 300 years ago. The image above is the "Davidson" Double Optometer patented



in 1893 and manufactured for the general practitioner. It was named after the firm of F Davidson that provided a range of ophthalmic instruments from 140 Great Portland Street, London, W1. It is a simple instrument made of wood in which the lenses from minus 8D to plus 7D were placed around the circumference. Additional spherical or cylindrical lenses could be placed in a single cell lens-holder behind the chosen lens in the wheel, to make a spherocylinder combination. The company's catalogue (fig.1) shows a test chart clipped to the stand and a set of cylinder lenses in a case in front of it. The wheel optometer of Davidson and others provided a quick method of introducing a lens in front of the patient's eye but only one eye could be tested at a time. Emile Javal (1839-1907) invented the optometer with two wheels, one in

front of the other (fig.2). One wheel contained a range of plus and minus spherical lenses, the other cylinder lenses. Through brilliant, precision engineering the axis of each of the cylinder lenses could be rotated by turning the lower brass knob. The axis of the cylinder was read from the pointer on the upper dial. In the 1880s a Swiss company introduced, a Double optometer (fig.3) with each side having two wheels one in front of the other, like the Javal Optometer. However, the cylinders could not be rotated, reducing its accuracy. The wheel optometer was the forerunner of the modern phoropter.

This image was provided to the Br J Ophthalmology by courtesy of Richard Keeler and published on Cover of BJO Dec 2011. It is reproduced here.

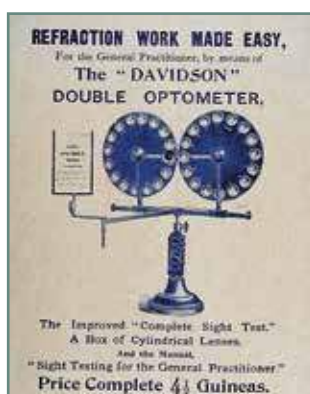

Fig.1 ▶ The company's catalogue



Fig.2 ▶ Optometer with two wheels



Fig.3 ▶ Double optometer

# FOCIMETER: FOCUSING ON POWER



Focimeters allow accurate determination of the spherical and cylindrical power of lenses and also indicate the axis of the cylinder. The first fociometer or lensmeter was designed by Hermann Snellen in 1876 and was known as a phakometer (fig.1). It was constructed by Dirk B Kagenaar (1842-1927) in the laboratory of the Eye Hospital in Utrecht. It very much resembles an optical bench.

The fociometer illustrated here was manufactured by Carl Zeiss, Jena in about 1920. This stand mounted fociometer was self-illuminated with

the instrument set at an angle to its base for operational ease and comfort. In use, the lens to be measured was placed in the middle of the instrument above the rectangular bar, which supported the edge of the lens and could be moved up and down for accurate centration. A cylindrical drum on the right was turned until a graticule in the eyepiece came into focus. The spherical and cylindrical power was read off an indicator on the drum.

Reproduced/adapted from Br J Ophthalmol, Fociometer, R. Keeler, A. Singh, H. Dua, 92, 593, May 1 2008 with permission from BMJ Publishing Group Ltd.



Fig.1 ► *The first fociometer or lensmeter*  
(Tonkelaar, Henkes, van Leersum 1996)

# TEACHING OCULAR PATHOLOGY: GLASS TO GLASS JARS



Most practising ophthalmologists today will recall looking at or studying eye pathology specimens preserved in glass jars in pathology museums. The image above illustrates a set of glass shells showing diseases and abnormalities of the eye, hand crafted in the late 1920s by ocularists in the ophthalmic drawing department of Theodore Hamblin Ltd at 15 Wigmore Street, London.

Unlike artificial eyes first described by Ambroise Paré 1510-90, the famous French surgeon, which fitted the socket of the eye and before cameras could capture images of external or internal eye diseases, this set fulfilled an important role in teaching students pathological conditions of the external eye.

The basic method of manufacture was the same as for artificial eyes invented by German craftsmen in 1835. To make these glass eyes a bulb was formed by heating the end of a tube of glass. Great skill was then employed to construct and paint the various conditions shown in the photograph.

Paintings of such conditions had been used since the second half of the 19<sup>th</sup> century and atlases of the fundus in colour had been available since 1863

when Richard Liebreich published the first atlas. Colour photography on glass plates of the external eye was difficult although Maitland Ramsay of Glasgow achieved outstanding results of patients' eyes up to and during the First World War. The first colour fundus photographs appeared in 1925.

In 1936 Kodachrome was invented and opened up a new convenient way of teaching diseases of the eye. The set shown here however captured dramatically the three-dimensional aspect of diseases that was not possible in prints and paintings. Some descriptions are enumerated below: Top row: (2) Ekzem (eczema) of the conjunctiva and cornea; (3) Egyptian disease of the eye. Second row: (2) Foreign body on cornea; (6) Spring Catarrh. Third row: (4) Siderosis; (5) Panophthalmitis caused by pick splint broken in vitreous body; (6) Rupture of one ekzem-pustule through the cornea with inveteracy in the iris (iris prolapse). Bottom row: (3) Staphyloma racenosum corneae; (6) Old macula cornea after ekzem.

Reproduced/adapted from Br J Ophthalmol, Teaching ocular pathology:glass to glass jars, R. Keeler, A. Singh, H. Dua, 92, 921, Jul 1 2018 with permission from BMJ Publishing Group Ltd.

# WOOL OVER EYES: HOLMGREN'S SKEINS AND THOMSON'S STICK



Fig.1 ► Holmgren wool colour test

Acuity of vision, field of vision and colour vision are the three most important attributes of human sight. Of these, colour vision is the most appreciated (imagine a world without colours), but least tested in routine ophthalmic examinations.

Tests for colour blindness go back to the time of Ludwig Seebeck in 1837. The first monograph on the subject was by George Wilson, regius Professor of Technology in Edinburgh in 1855. He pointed out that a colour blind person cannot be a painter, tailor, chemist, botanist, geologist or physician and to this list he added ship's pilots and railroad engineers. In the same year the Great Northern Railway undertook the testing of thousands of their employees for colour blindness.

Following a major railway accident in Sweden in 1877 and a suspicion that it was caused by colour blindness, Frithiof Holmgren (1831-1897), a Swedish physiologist of Uppsala, devised his colour wool test which was to become the standard method of testing for colour blindness.

His test comprised three skeins of wool, green, rose and deep red (fig.1). With the green skein the person being tested had to pick the same colour, not shade, from a number of other skeins of different shades of green, red and confusion colours of grey and brown. If there was any defect in colour vision the person would select a number of confusion colours, chiefly grey with some green tints but if green was selected the person was not

colour blind. The rose and red skeins were used to test the type of colour blindness.

The main illustration shows a derivation of Holmgren's test devised in 1880 by Dr William Thomson (1833-1907) of Jefferson Medical College and consultant at Wills Eye Hospital, Philadelphia. He wanted to devise a quicker test for the burgeoning railway network, especially the 40 000 men of the Pennsylvania Railway Co.

He called it the Thomson Stick. It consisted of two flat sticks two feet long with 40 strands of coloured wool skeins hanging from it.

As with the Holmgren Test the patient first had to pick the same colour as the green skein. Each of the 40 skeins has a number; the first 20 are green, grey and tan colour confusion strands. The next 10 colours are rose and blue and the final 10 tints red and confusion colours. As the patient picked each colour the skein would be folded over the stick revealing a number on the reverse. Even numbers would demonstrate a defect in colour vision.

Today these tests are replaced by the popular Ishihara (Dr Shinobu Ishihara) colour plates and the Farnsworth Munsell 100 hue test and their numerous manual, automated and digital variations.

Reproduced/adapted from Br J Ophthalmol, 'Wool over eyes': Holmgren's Skeins and Thomson's Stick, R. Keeler, A. Singh, H. Dua, 93, 32, Jan 1 2009 with permission from BMJ Publishing Group Ltd.

# PRESSURE TO MEASURE PRESSURE: THE McLEAN TONOMETER



Fig.1 ► The McLean tonometer

Albrecht von Graefe's invention of the surgical iridectomy procedure for the treatment of glaucoma in 1857 was his impetus to design an instrument to measure the eye pressure so that he could record pressures before and after iridectomy. He also constructed a campimeter for plotting the visual field. His design for a pressure measuring instrument was developed into the first tonometer in 1863. It was however unsuccessful. This was followed by several attempts and a series of tonometers by Frans Donders and others over the next 20 years. The problem they all had was a lack of accuracy due to variable friction in the moving parts of the instrument and the fact that the probe had to be applied through the eyelid, introducing further uncontrollable variables.

Carl Koller's discovery of cocaine as a local anaesthetic in 1884 allowed the next series of tonometers that made direct contact with the cornea. The emphasis was on indentation tonometers, despite the difficulty and inaccuracy associated with their use. The introduction of Hjalmar Schiøtz's tonometer in 1905 eased some of the major problems. Even at that early stage Alexei Maklakov introduced his applanation

tonometer, which too became popular.

The McLean tonometer (fig.1) was constructed to improve or eliminate certain deficiencies in the Schiøtz tonometer. The instrument was made for Dr McLean by EB Meyrowitz of New York. In an article written by William McLean<sup>1</sup>, he listed the following features:

- To avoid the changing of weights as in the Schiøtz and Gradle tonometers
- Elimination of the chart to determine the pressure in millimetres of mercury
- To place the reading scale in a position to make it easier for the observer to both apply the instrument and take a reading
- To try and prevent capillary attraction between the plunger on the tonometer and its barrel from fluid in the conjunctival sac

McLean also read a paper on his tonometer at the Oxford Ophthalmological Congress in July 1919<sup>2</sup>.

The Schiøtz tonometer however remained a popular instrument in clinical practice and is still used in some parts of the world.

Reproduced/adapted from Br J Ophthalmol, Pressure to measure pressure: the McLean Tonometer, R. Keeler, A. Singh, H. Dua, 93, 1131, Sep 1 2009 with permission from BMJ Publishing Group Ltd.

1) Professor of Ophthalmology at New York Medical College MD in the American Journal of Ophthalmology, June 1919

2) Published in the British Journal of Ophthalmology 1919;3:385-99

## THE STEREOSCOPE: SCOPING THE THIRD DIMENSION



Today, for many it is difficult to imagine a world without television. Yet it was not that long ago when none existed, and people indulged their fascination with images using simple devices such as stereoscopes. Stereoscopes allowed three-dimensional viewing of "flat" two dimensional images. The image above is a fine example of a stereoscope, made in rosewood, which was used in homes in the middle of the 19<sup>th</sup> century as a form of amusement equivalent to today's television. It consisted of a pair of plus lenses through which the viewer focussed on a card with two identical photographs on a holder which could be moved backwards and forwards to bring the photographs into focus. Some of us may remember from our childhood days, the street vendors who would for a few pence or paise, allow us to use the peep-holes in their contraptions rightly or wrongly called "biscopes" that took us on a tour of the world. Thousands of paired photographs were sold on a wide variety of subjects. The cards lying on the table beside the stereoscope were mounted

on a different form of stereoscope used for the training of muscles of the eye in squint, to promote binocular fusion reflexes.

The claim to the original invention of the stereoscope involved a prolonged and acrimonious public debate between two of the greatest scientists of the day, Sir David Brewster and Sir Charles Wheatstone. Wheatstone (fig.1) was certainly the first to explain the principle of perceiving depth with his mirror stereoscope presented at the British Association in 1838. Brewster claimed priority when he substituted mirrors (later prisms) with lenses to create his lenticular stereoscope in 1849. The significance of the stereoscope in ophthalmology stems from derivations of the Brewster stereoscope. David Brewster (1781-1868) was once referred to by George Airy as the father of modern experimental optics. He was the inventor of the immensely popular kaleidoscope in 1815 and was an early investigator of the anatomy of the eye.

Like many "inventions" Leonardo da Vinci in about 1500 had already foreseen that it was possible to obtain stereoscopic depth from a picture. It was the American physician Oliver Wendell Holmes (1809-1894) (fig.2) who developed and popularised the first stereoscope with cards such as the one showing the parrot in one half of the image and the cage in the other (see card in image above). Edward Oatman MD in his three-volume book on Diagnostics of the Fundus Oculi (fig.3) in 1920 used a Holmes Stereoscope to demonstrate fundus conditions in three dimensions. Then followed Worth's amblyoscope

paving the way for various forms of synoptiscopes or synoptophores used by orthoptists. They all used the same principle as the original stereoscope conceived by Wheatstone. Charles Wheatstone (1802–1875), is best known for his pioneering work on electricity. He also brought the world's attention to the Czech physiologist Jan Evangelista Purkyne's work by translating his thesis into English. He has over 100 objects named after him in the Science Museum.

Reproduced/adapted from Br J Ophthalmol, The Stereoscope, R. Keeler, A. Singh, H. Dua, 93, 283, Mar 1 2009 with permission from BMJ Publishing Group Ltd.



Fig.1 ▶ Sir Charles Wheatstone



Fig.2 ▶ Oliver Wendell Holmes

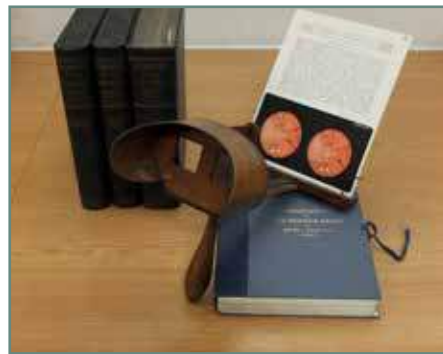
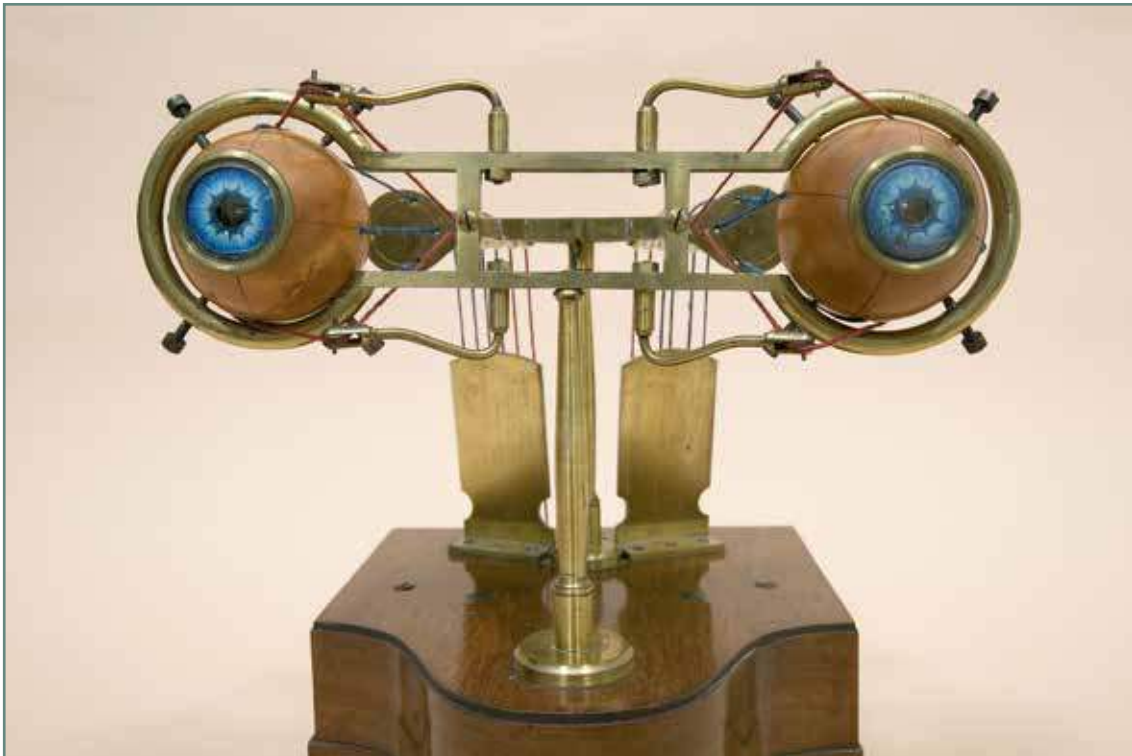

Fig.3 ▶ Book on Diagnostics of the Fundus Oculi

# OPHTHALMOTROPES: THE EYE IN MOTION



The eye has a unique position in head and neck anatomy with six of the twelve cranial nerves serving the globe and adnexa, in whole or in part. Three nerves on each side are dedicated entirely to the six oculomotor muscles that enable complex and co-ordinated ocular movements, extending the field of vision. Understanding muscle actions, the different movements they induce in different positions of the eye along the horizontal (elevation/depression) vertical (right/left) and antero-posterior (torsion) axes can be daunting to say the least. It is not surprising therefore that ophthalmologists of the 19<sup>th</sup> century should have sought a practical solution with the construction of mechanical models.

An ophthalmotrope (ophthalmos, eye - trope, turning) is a mechanical model constructed to demonstrate the movements of the eye and the action of the different muscles which produce them.

The first functioning model to demonstrate eye movements was made by Theodor Ruete (1810-1867) (fig.1) in 1845 and he christened it the

"ophthalmotrope". Frans Donders (1818-1889) became interested in eye movements on reading Ruete's work, and his subsequent studies were of physiological interest and also provided the basis for principles underlying the correction of squint. There followed several "laws" relating to muscle interaction, the best known being Donders's Law and Listing's Law. Donders' law states that for any one gaze direction, the eye always assumes the same unique orientation in 3 dimensions. This is the same no matter where the starting position of the eye was and is driven by the nerves.

Ruete's second model of 1857 (above and fig.2), is an altogether more sophisticated model that demonstrates both the movements of the eye and, importantly, the action of the ocular muscles. The eyeballs, made of palm wood, contain lenses, and at the back of the eye there is an opaque screen with a cross on it. The optical system can be moved backwards and forwards to simulate accommodation. Black and red coloured threads represent the muscles, the



red ones being the oblique muscles and the black the rectus muscles. The degree of muscle contraction or extension can be measured on a scale at the back of the model.

Other ophthalmotropes were constructed by Knapp (fig.3), Wundt, Donders and Landolt. Edmund Landolt (1846-1926) gave the name ophthalmotrope to his instrument (fig.4) but it is more of a demonstration model to show the controversial "centre of rotation of the eye". It has different coloured rods indicating the central axis of rotation when clamped between the

respective adjustment screws. The instrument can represent either eye. Landolt was a pupil of Frans Donders in Utrecht who produced a series of what he called phaenophthalmotropes (fig.5).

Incidentally, Ruete who invented the first ophthalmotrope, also invented the first indirect ophthalmoscope in 1852 and published a detailed description on the method of indirect ophthalmoscopy.

Reproduced/adapted from Br J Ophthalmol, Ophthalmotropes: the eye in motion, R. Keeler, A. Singh, H. Dua, 93, 572, May 1 2009 with permission from BMJ Publishing Group Ltd.



Fig.1 ▶ Theodor Ruete



Fig.2 ▶ Ruete's second model of 1857

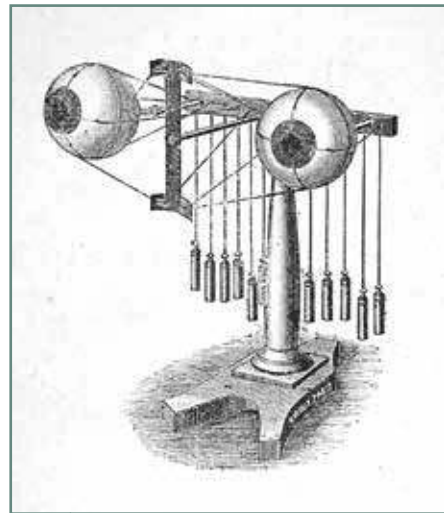

Fig.3 ▶ Ophthalmotropes constructed by Knapp



Fig.4 ▶ Edmund Landolt's instrument



Fig.5 ▶ Phaenophthalmotropes (Tonkelaar, Henkes, van Leersum 1996)

# CARVING THE CORNEA: THE VON HIPPEL TREPHINE



Fig.1 ▶ Arthur von Hippel



Fig.2 ▶ The von Hippel trephine in use



Fig.3 ▶ Eduard Zirm

The von Hippel trephine was invented around 1888 by Arthur von Hippel, a distinguished German ophthalmologist (1841-1916) (fig.1). Arthur von Hippel graduated as a doctor of medicine and surgery in 1865 and went on to study in Prague, Paris and Vienna. It was here that he came under the influence of Hugo von Arlt who persuaded him to specialise in ophthalmology, an under-recognised subject at the time. He served as Professor of Ophthalmology at the University of Giessen and in 1890 succeeded his mentor, Professor Jacobson at Königsberg. He worked in Königsberg until 1901 when he moved to Göttingen where he built the new eye clinic.

The main feature of the von Hippel Trephine was a clockwork mechanism, which activated the rotation of a circular blade allowing the surgeon to hold the instrument firmly in a perpendicular position to the cornea. To use the instrument the surgeon held it by the column with the forefinger placed on the small knob at the top. Depression of this knob released the clockwork coil inside the cylinder thereby rotating the blade.(fig.2)

The ornate key had two functions, one to wind up the mechanism and secondly to secure the adjustable depth of the cut by tightening the screw on the blade holding column.

Corneal trephine blades of different diameters, 4, 5 and 6 mm were provided on the early models and later scleral trephines were included.

In 1888 von Hippel published a paper titled "Eine neue Methode der Hornhauttransplantation" (A new method for cornea transplantation) describing his technique of lamellar inlay grafts. This paper opened the way for the first successful full thickness corneal transplant some years later but von Hippel is credited with being the first to transplant corneal tissue in a human whilst retaining transparency of the graft.

The first full thickness graft from donor material was performed by Eduard Zirm (fig.3) using a von Hippel trephine. The patient, Alois Glogar, had been blinded in both eyes by an accident with unslaked lime. The eye was operated on in 1905 using a 5 mm trephine blade which was used on both the enucleated donor eye and the patient's recipient eye.

Reproduced/adapted from Br J Ophthalmol, Carving the cornea: the von Hippel Trephine, R. Keeler, A. Singh, H. Dua, 93, 847, Jul 1 2009 with permission from BMJ Publishing Group Ltd.

# ANATOMICAL EYE MODEL



Medicine, like any discipline, requires not only the acquisition of knowledge but also its retention for future reference and for use by others that follow. What better way to learn about the human body than by dissecting a human body? By the 16<sup>th</sup> century dissection of the human body became commonplace and "art joined medicine"<sup>1</sup> as a means of recording information. Leonardo da Vinci was among the many artists who dissected human bodies and made meticulous recordings of his observations both in text and images. "By the 18<sup>th</sup> century, every medical student did dissection, and only one tenth of those corpses came from legal sources".<sup>1</sup> "Grave robbing" became an established means of acquiring bodies for dissection. Clearly this was unacceptable and had other disadvantages too. Bodies were in short supply and could only be used once. Alternative options were needed.

The history of models used for teaching dissection and anatomy as a cheaper and more readily available source than cadavers goes back to the middle of the 18<sup>th</sup> century when they were made of wax. Dr Louis Auzoux (1797-1880), an anatomist and physician, having experienced the fragile nature of wax models during his medical student days, set up a company to make papier-

mâché models shortly after he received his medical degree.

This papier-mâché *modele d'anatomie clastique*, from the Greek word "klastos" meaning "broken in pieces", was one of many examples of parts of the human body made by Louis Auzoux at his factory in Normandy, which he established in 1828.

His invention of a secret mixture of cork, clay, paper and glue, hand painted by expertly trained artists allowed the models such as this eye to be disassembled and reassembled again and again. The model is extensively marked with numbers allowing the student to learn the intimate details of the anatomy of the eye.

Late in the 19<sup>th</sup> century the costly papier-mâché technique gave way to models made of plaster, and today the inevitable plastic.

This eye model can be seen at the museum of the Royal College of Ophthalmologists and was originally used in the old Glasgow Eye Infirmary. It was supplied to them sometime in the middle of the 19<sup>th</sup> century by John Weiss and Son Ltd, surgical instrument makers of London.

Reproduced/adapted from Br J Ophthalmol, Anatomical eye model, R. Keeler, A. Singh, H. Dua, 92, 1179, Sep 1 2008 with permission from BMJ Publishing Group Ltd.

1. Lienhard JH. Engines of our ingenuity. No 301: Art and dissection. <http://www.uh.edu/engines/epi301.htm>

# TRAIL OF TRIAL LENSES



The itinerant spectacle seller was using trial lenses in the form of pairs of lenses held in a frame as early as the 17<sup>th</sup> century (fig.1). In 1838 George Cox, an optician in England, combined eight or nine frame fronts with lenses of varying powers clamped together at one corner by a rivet. The opened out like a fan. These were called trial boxes and allowed the examiner to flip between frames to speed up the examination process. Each frame had its focal length in inches stamped on it (the dioptre was not introduced until 1874). There were a variety of "boxes" of convex and concave powers many made in tortoiseshell. In 1860 Frans Donders mentioned that Albrecht von Graefe had boxes marked with the same number as his optician, making prescribing by numbers easy! In 1843 Georg Frömmüller of Furth put together a case of trial lenses consisting of 60 pairs of lenses with its

own trial frame. For the first time it was possible to prescribe lenses of different powers for each eye.

Another instrument used by the public to assess their required power of lenses was the Subjective Refractor c1900 (fig.2). This instrument was operated by the patient turning a brass knob which moved pairs of lenses into position behind the eyepiece on a chain loop and the patient read the word chart at the end of the unit to ascertain the sharpest image. Miniature travelling trial cases and frame were also developed (fig.3). Although test charts designed by Küchler, von Jaeger and von Carion were being used before Snellen's Optotypes of 1862, his was the first to bring a scientific standardisation to the measurement of visual acuity.

Reproduced/adapted from Br J Ophthalmol, Trail of trial lenses, R. Keeler, A. Singh, H. Dua, 92, 1449, Nov 1 2008 with permission from BMJ Publishing Group Ltd.



Fig.1 ► *The itinerant spectacle seller*



Fig.2 ► *Subjective Refractor c1900*



Fig.3 ► *Miniature travelling trial cases and frames*

# ELECTRIC EYES: WIRTZ IONTOPHORESIS ELECTRODES

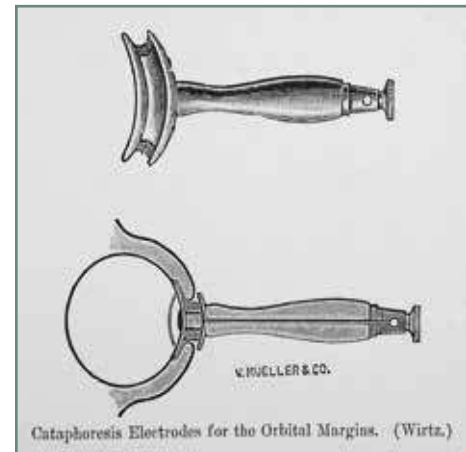

Fig.1 ▶ The line drawings illustrate the application of the electrodes and the large area of contact

The "shock" experienced by touching certain fish (electric fish) is described in ancient Egyptian texts dating from 2750 BC.<sup>1</sup> Arab physicians attempted to provide relief from pain of gout and headaches by instructing patients to touch these fish in the expectation that the energy thus transferred would cure them of their ailment. The first study of electricity applied to the eye was in 1855 by the Frenchman B. Duchenne. He noted that a continuous application of 1.4 milliamps of current to the eye affected light and colour sensitivity. The visual field for both white light and colour appeared to enlarge. Certain responses in the muscles were also noted.

Drug penetration into the eye was a recognised issue even in the early days. The exposed location of the eye prompted attempts to use electricity to improve penetration of medicines, a practice referred to as cataphoresis (iontophoresis). Certain ions like zinc, copper and mercury could penetrate deeper into the eye with the assistance of an electric current. In 1908 Dr Robert Wirtz used iontophoresis for the treatment of certain eye diseases.<sup>2</sup> The photograph above shows the special set of variously shaped cathodes that Wirtz designed. Because of the extensive area of contact, a large surface was available for the therapeutic agent to penetrate to the internal part of the eye (fig.1). The

handles were made of celluloid with the current entering one end while the other was covered by thick layers of muslin saturated with the dissolved medication being used. It was emphasised that the medication should be diluted in distilled water to facilitate flow of electricity. Wirtz was particularly encouraged by the beneficial effect he achieved in serpiginous ulcer of the cornea which he treated with 0.5% zinc sulphate for one minute at 2 milliamps. Interstitial keratitis was treated with 1% sodium iodide solution and for episcleritis he used chlorine ion from a 0.9% sodium salt solution.

The success of iontophoresis encouraged others to develop alternative designs. One consisting of glass cylinders with different end shapes that could be filled with the desired solution was developed by Stocker and Birkhauser. This method of therapy was short-lived and by 1920 the treatment by iontophoresis had become unfashionable and rarely used.

Today, electricity is used for cutting and coagulating tissue and destroying the roots of undesired hair follicles. Study of the eyes' internal electric currents is widely used in electrodiagnostics and has even been put forth as an explanation for the "whorl" or vortex patterns seen on the corneal surface.<sup>3</sup>

Reproduced/adapted from Br J Ophthalmol, Electric Eyes: Wirtz iontophoresis electrodes, R. Keeler, A. Singh, H.S. Dua, 93, 1415, Nov 1 2009 with permission from BMJ Publishing Group Ltd.

1. <http://en.wikipedia.org/wiki/Electricity>

2. Wirtz, Robert: Die Ionotherapie in der Augenheilkunde. Klin Mbl Augenheilk (Nov/ Dez1908).

3. Dua HS, Watson NJ, Mathur RM, et al. Human corneal epithelial cell movement in vivo: "Hurricane" and "Blizzard" keratopathy. Eye 1993;7:53-8.

# CALCULATING CURVES: KERATOMETERS AND OPHTHALMOMETERS



Fig.1 ▶

Hermann von Helmholtz  
Ophthalmometer, 1854  
("Eye and Instruments":  
Tonkelaar, Henkes, van  
Leersum 1996)

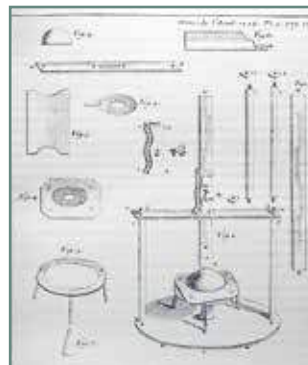

Fig.2 ▶

Francois-Pourfour  
du Petit's "cadaver"  
Ophthalmometer,  
1728

An ophthalmometer measures the optical constants of the eye and is derived from the Greek words, *ophthalmos*-the eye and *metros*-the measure. A keratometer only measures the curvatures of the anterior surface of the cornea. It provides information on the spherical and astigmatic components of the corneal curvature and also the axis of astigmatism. Hermann von Helmholtz is credited with the invention of the first ophthalmometer in 1854 (fig.1), 3 years after the invention of the ophthalmoscope. Frans Donders used von Helmholtz's instrument to conduct his ground breaking research on the dioptrics of the eye. However, Francois-Pourfour du Petit (1665-1741), a French ophthalmologist had probably beaten von Helmholtz to the invention of what would technically be an ophthalmometer in 1728. His instrument was used to calculate, in what turned out to be incredibly accurate manner, the power and axial measurements of cadaver eyes (fig.2). The Keratometer works on the principle that the human cornea, polished by its thin tear film, produces a brilliant convex mirror-like surface. This reflects translucent mires or targets directed towards it. These mires are viewed through a high powered telescope within which is held an optical doubling device such as a Wollaston prism. As the mires are brought

together, measurements for the radius of corneal curvature in millimetres and power in dioptres can be taken in the two meridians. Difference in measurements in the two meridians provides the value of astigmatism together with its axis. Jesse Ramsden was the first to construct an optical keratometer. He used this in experiments which persuaded him to lend support to Joseph Kepler's theory that accommodation occurred in the cornea. He was so wrong but one cannot blame his instrument! The first practical ophthalmometer was developed by Emile Javal (1880) who joined forces with Hjalmar Schiötz in 1881 and produced several models that were widely used in the last two decades of the 19<sup>th</sup> century culminating in the instrument made by Pfister and Streit, later Haag Streit, in 1900. The instrument shown above is the Hardy keratometer made by the FA Hardy Company of Chicago in 1900. The instrument was designed and patented by Messrs John Chambers and Charles Innskeep in 1899.

Today keratometers are invaluable in the fitting of contact lenses, intraocular lens implant power calculation and corneal refractive surgery.

Reproduced/adapted from Br J Ophthalmol, Calculating curves: keratometers and ophthalmometers, R. Keeler, A.D. Singh, H.S. Dua, 94, 1144, Sep 1 2010 with permission from BMJ Publishing Group Ltd.

# REFLECTING ON REFLECTIONS: GULLSTRAND'S LARGE REFLEX-FREE OPHTHALMOSCOPE



*Allvar Gullstrand with his ophthalmoscope  
(photo, courtesy of Swedish Society of  
Medicine)*

Professor Allvar Gullstrand's large reflex-free ophthalmoscope was first produced by Carl Zeiss Jena in 1911. The model shown above is a later, improved, version. A "reflex" refers to an image formed by a reflection. The cornea can produce annoying reflexes that interfere with visualisation of objects behind it. The fundus too produces a reflex, which manifests as a red glow filling the pupillary aperture. Overcoming the interference caused by "reflexes" was a major step forward in the evolution of ophthalmoscopes. The optical principle employed to eliminate corneal reflexes was the projection of the focused illuminating beam through the lower section of the dilated pupil while the observer viewed the fundus through the upper half. Monocular and binocular versions were produced. Other accessories such as an observer's eye-piece and a fundus drawing apparatus were also provided. The instrument was later the basis for the Nordenson Fundus Camera produced in 1925.

Professor Walter Thorner was the first to design a reflex-free ophthalmoscope in 1896 but the Zeiss-Gullstrand instrument was more successful mainly due to the provision of a stronger source of illumination. Walter Thorner, working with the Busch Company later patented a small hand held reflex-free instrument.

The development of the bulb and the incorporation of batteries in the instrument handle were significant advances which allowed

ophthalmoscopes to become compact and smaller paving the way for the modern versions. The versatility, ease of use and high quality of images of modern ophthalmoscopes disguise the arduous and painstaking evolution of this incredible instrument.

The particular instrument shown here had been abandoned in East Africa. It was brought back to England after the War by Mr Arthur H Osmond, later a consultant ophthalmologist at the Sussex Eye Hospital who donated it to the hospital in the 1980s. The hospital recently presented it to The Royal College of Ophthalmologists' museum where it was refurbished.

Allvar Gullstrand (1862-1930) was Swedish born and by profession was a physician. He became Professor of Ophthalmology in Uppsala in 1894. It was in 1911 that he was honoured by being awarded the Nobel Prize in Physiology/Medicine for his work on dioptrics of the eye. This self-taught man made a major contribution to the knowledge of astigmatism and in conjunction with Carl Zeiss, Jena, he invented a series of important ophthalmological instruments including the Slit Lamp and the subject of this article, the Large Reflex-Free Ophthalmoscope, which was the forerunner of fundus photography.

Reproduced/adapted from Br J Ophthalmol, Reflecting on reflections: Gullstrand's large reflex-free ophthalmoscope, R. Keeler, A.D. Singh, H.S. Dua, 94, 826, Jul 1 2010 with permission from BMJ Publishing Group Ltd.

## DISC-FULL OF DRUGS: COMPRESSED OPHTHALMIC DISCS



Drug delivery to the eye has always been a matter of interest and innovation. One such endeavour is illustrated above, which shows a set of 24 circular boxes made in bone, with each box containing discs of different drug preparations in compressed form. These 3 and 5 mm discs were sometimes referred to as "lamels".

The discs were made in the late 19<sup>th</sup> century, at the instigation of Dr Casey Wood,\* by a company based in Philadelphia, John Wyeth and Brother. The set of discs in the box illustrated belonged to Dr Maitland Ramsay (1859-1946) of the Glasgow Eye Infirmary, UK. He was author of the outstanding Atlas of External Diseases of the Eye.<sup>2</sup>

Medication in the discs was used for a variety of ocular indications and included atropine sulphate, muriate of morphia, pyoktanin (an antiseptic), gelsemine alkaloid (a mydriatic), daturine (atropine), muriate of cocaine, duboisine (a mydriatic stronger than atropine) (fig.1) and eserine sulphate. Drugs such as atropine sulphate were provided at different strengths from 1:2500 to 1:250 g per disc (see here for a full list).

**343 Hyoscyamine Sulphate** - strong dilator of the pupil (mydriatic).

**311** Combination of products for dilation and anaesthesia.

**361 Morphia Muriate - Morphine Hydrochloride** - contraction of the pupil.

**333 Ergotine** - Use in the eye is not mentioned in Martindale. It contracts blood vessels and thus may have been used for haemorrhage.

**356 Pyoktanin Blue** - Methylene Blue - antiseptic.

**334 Gelsemine Alkaloid** - contraction of the pupil.

**346 Hyd. Chlor. Corros.** - Mercuric Chloride - antiseptic.

**352 Pilocarpine Alkaloid** - contraction of the pupil

**366 Silver Nitrate** - astringent - inflamed eye conditions.

**315 Acid Boric, Camphor, Plumb. Acetas** (Lead Acetate) - antiseptic, soothing and astringent.

**338 Homatropine Alkaloid, Cocaine Alkaloid** - Dilator + anaesthetic.



**380 Iodoform** - antiseptic.

**326 Daturine** - dilator of the pupil.

**304 Atropine Sulphate** - dilator of the pupil.

**330 Eserine Sulphate** - contraction of the pupil.

**327 Duboisine** - dilator of the pupil.

**348 Hyd. Chlor. Corros.** - Mercuric Chloride antiseptic (as 346).

**367 Silver Nitrate** - astringent - inflamed eye conditions (as 366)

**322 Cocaine Muriate** - Cocaine Hydrochloride - local anaesthetic.

**325 Cupri Sulphas.** - Copper Sulphate - haemostatic (stops bleeding).

**332 Eser. Sulphate, Cocaine Muriate** - contraction + anaesthetic.

**317 Mercurous Chloride** - antiseptic

Each thin disc measured 3.1 mm in diameter or in some cases 5 mm. It was generally inserted into the corner of the eye or under the inner surface of the lower lid with the aid of a camel-hair brush. It quickly dissolved into the lachrymal fluid, allowing the drug to access the tissues of the eye. Patients with dry eyes may not have fared very well.

Reproduced/adapted from Br J Ophthalmol, Disc-full of drugs: compressed ophthalmic discs, R. Keeler, A.D. Singh, H.S. Dua, 94, 283, Mar 1 2010 with permission from BMJ Publishing Group Ltd.



Fig.1 ► *Duboisine (in the circular container)*

1. Martindale, Westcott. The extra pharmacopoeia. 10th edn. 1901.

\* Casey Albert Wood (1856-1942) was born and educated in Canada. He rose to fame after moving to Chicago in 1889 where he became Professor of Clinical Ophthalmology at the Post Graduate Medical School. Later, he was Professor of Clinical Ophthalmology at the College of Physicians and Surgeons and Professor of Ophthalmology at Northwestern University. He was a prolific writer and editor of several journals, including the 18-volume American Encyclopedia of Ophthalmology.

2. Ramsay Maitland, Atlas of External Diseases of the Eye.

## ALL FOR A DROP: UNDINES AND DROP BOTTLES



Drops, ointments, gels, inserts and sprays are established modes of administering medication to the eye. Doctors and patients will not pause to give a second thought when instilling a drop of any drug in the conjunctival sac. It is difficult to comprehend that there was a time when this simple act was a challenge. What we take for granted today, required elaborate containers called "Undines" and "Drop bottles".

The clear glass container on the left of the above photograph is an undine. In mythology an "Ondine" or "Undine" refers to a female water spirit or water elemental. Paracelsus, a Swiss Physician of the 16<sup>th</sup> century, coined the term undina in his writings, derived from the Latin word unda, meaning 'a wave'. Undines are more popularly known as mermaids and it is generally believed that an undine or mermaid can get a soul only by marrying a man and bearing his child. In German folklore, an Ondine punished her unfaithful husband with a curse that he would stop breathing if he went to sleep. This tale is the basis of "Ondine's Curse", the term used to describe congenital central hypoventilation

syndrome in which the patients lose autonomic control over breathing and are at greatest risk of respiratory arrest when asleep.<sup>1</sup>

In ophthalmology these elegantly designed containers were filled with sterile saline solution and were used to flush blood and other material from the eye during surgical operations. They were made in many shapes and sizes including a miniature metal kettle. Their common characteristic was the thin spout which allowed the jet of water to be directed very precisely (fig.1).

The coloured drop bottles shown were just three of a number in general use in the first half of the 20<sup>th</sup> century. They were used to hold drugs in dilute form, those on the image above were for atropine, eserine and euphthalmine. Each bottle was colour coded; euphthalmine in the green bottle, like atropine (blue) caused mydriasis but acted on the iris alone. Eserine in the ruby bottle was a stronger miotic than pilocarpine. Other drop bottles illustrated in the rack were used for adrenalin, cocaine, fluorescein and homatropine (fig.2).

The rack of bottles was the idea of L Vernon Cargill FRCS (1866-1955) House Surgeon to Lord Lister at King's College and consultant at The Royal Eye Hospital. His method of sterilising the solutions is illustrated in fig.3. He wrote:

*"The contained solutions may be sterilised from time to time by removing the cap, reversing the pipette, and allowing the contents to boil slowly for three minutes, after which distilled water should be added to compensate for loss of solution in the bottle."*

Reproduced/adapted from Br J Ophthalmol, All for a drop: Undines and drop bottles, R. Keeler, A.D. Singh, H.S. Dua, 94, 26-27, Jan 1 2010 with permission from BMJ Publishing Group Ltd.



Fig.1 ▶ Undines of different shapes and sizes. The flow through the spout could be controlled by pressure on the diaphragm or blocking the opening of the straight arm with a finger tip

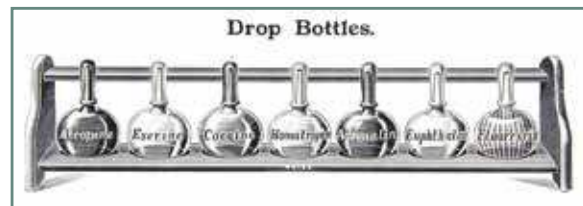

Fig.2 ▶ A rack of drop bottles, which were colour coded for commonly used drugs

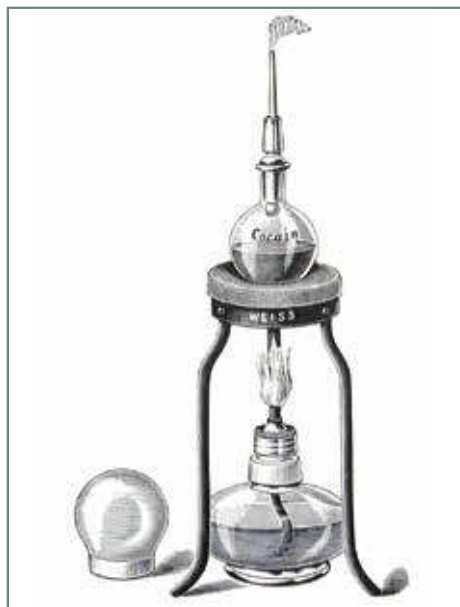

Fig.3 ▶ Sterilisation of the contents of drop bottles by boiling

1. [http://en.wikipedia.org/wiki/Undine\\_\(mythology\)](http://en.wikipedia.org/wiki/Undine_(mythology))

## RECUMBENT SPECTACLES: TAKING IT LYING DOWN



Fig.1 ► Mr Andrew McKie Reid (1894-1973)



Fig.2 ► Recumbent spectacles in use

When one is forced to lie supine, flat on the back, for days on end, how does one pass the time? "By reading" is one obvious answer but even this simple task can become a practical challenge. The eyes can only stare at the ceiling and holding a book between the eyes and roof can be a tiring proposition.

In 1935 Mr Andrew McKie Reid (fig.1) designed the "recumbent spectacles", as a visual aid for patients suffering from spinal lesions and other diseases who were confined to the bed in a supine position for weeks or months. The spectacle consists of a pair of prisms mounted in a frame which could either be worn over the patient's own glasses or the refractive prescription could be incorporated in the frame. The prisms had an apical angle of 35 degrees and basal angles of 70 and 75 degrees. These angles were calculated such that a book held in the normal position on the chest (fig.2) could be read by a person in the supine position even though apparently looking at the ceiling. In

other words, with the base of the prism facing the patient, the line of vision through refraction and double internal reflection within the prisms was bent almost 90 degrees. Another model was available for the semi-supine patient.

The spectacle was made by Messrs Hamblin of Wigmore Street, London and was shown for the first time at the Oxford Ophthalmological Congress in July 1935.

Andrew McKie Reid, MC, TD, FRCS 1894 - 1973 was a Liverpudlian. His medical studies were interrupted by the First World War in which he was badly wounded and awarded the Military Cross. He spent his whole professional career at St Paul's Eye Hospital and served other non-medical institutions as well. He was Chairman of the Liverpool Philharmonic Society. He served on numerous medical societies and was Treasurer of the Faculty of Ophthalmologists.

Reproduced/adapted from Br J Ophthalmol, Recumbent spectacles: taking it lying down, R. Keeler, A.D. Singh, H.S. Dua, 94, 535, May 1 2010 with permission from BMJ Publishing Group Ltd.

# DETECTING DEFECTS: THE McHARDY PERIMETER



Fig.1 ► Malcom McHardy (1852-1913)

Instruments to detect defects in the field of vision, known as perimeters, were invented around 1870. The outlines of the limits of the visual field and of the defects within were transcribed by the examiner. In 1882, a self-registering perimeter was invented by Malcom MacDonal McHardy (fig.1), a consultant ophthalmologist at The Royal South London Hospital, later to be known as the Royal Eye Hospital.

The perimeter was made by the London opticians, (Pickard and Curry of 195 Great Portland Street, W1). The instrument consists of a revolving quadrant of a quarter arc whose radius is one-third of a metre. The arc permits measurement of the angle of the limit of the visual field in the meridian tested, and rotation of the arc allows any meridian to be tested. Earlier designs of other perimeters had hemispherical arcs. McHardy introduced the quarter-arc perimeter. The test object is within a disc with opening of 1, 2, 5, 10, 15 and 20mm, over which is superimposed a choice of colours so that any combination of opening and colour can be set.

This disc combination is moved along the arc by cords operated by the examiner. The positions in the arc are recorded by the patient pressing a sharp metal point into a chart held within a holder each time the target moves out of view. A candle within the small box is used for the light test.

Professor Malcom McHardy (1852-1913) was the grandson of Thomas Masterman Hardy, Horatio

Nelson's flag-captain on HMS Victory. He studied at St George's Medical school, getting his MRCS in 1873 and FRCS from Edinburgh, 2 years later. He succeeded Edward Nettleship as assistant ophthalmic surgeon at The Royal South London Ophthalmic Hospital, going on to be full surgeon as well as having an appointment as professor at King's College Hospital. He was consultant at the hospital until 1909.

This larger-than-life ex-boxer, with enormous energy, was known for his dexterity with the knife, operating equally well with his left or right hand. He was the first to remove a chip of steel in a patient's lens with the electro magnet.

The firm of Pickard and Curry opened in 1876 as "Surgeons" opticians' in the West End of London and soon earned a reputation as outstanding ophthalmic instrument-makers. Apart from the McHardy perimeter, they also made a range of other instruments and ophthalmoscopes, including John Couper's famous chain-of-lenses ophthalmoscope. In 1890, the company became Curry and Paxton.

The McHardy perimeter was one of the most popular instruments in the early years of perimetry development, which started with the Aubert/Förster perimeter in 1869.

Reproduced/adapted from Br J Ophthalmol, Detecting defects: the McHardy Perimeter, R. Keeler, A.D. Singh, H.S. Dua, 95, 600, May 1 2011 with permission from BMJ Publishing Group Ltd.

## DOUBLING UP: TWO PRISMS, TWO NAMES, TWO COUNTRIES



Sir John Herschel, born in Slough, England in 1792, was a distinguished mathematician and astronomer. His father, German-born Friedrich Wilhelm Herschel (Sir Frederick William Herschel) discovered the planet Uranus. One of Sir John's many contributions to science was the concept that two prisms of equal power when rotated in opposite directions give gradually increasing power from zero to double the power of each individual prism. Based on this principle he developed an optical instrument with rotating prisms, for his astronomical work.

Crêtès, an optician from Paris was encouraged by an ophthalmologist, Louis de Wecker (1832-1906) to adapt Herschel's rotating double prism for ophthalmic use, which he accomplished in 1872. The double-prism was used for determining the degree of convergence and the strabismic angle in a squinting eye. Inspired by Crêtès' device, in the same year Herman Snellen asked him to mount two cylinders, one plano-convex and the other plano-concave in the same holder to produce the cross cylinder effect, the original idea for which is attributed to Sir George Stokes, Lucasian Professor at Cambridge.

The Crêtès-de Wecker rotary double-prism uses two prisms of  $8^\circ$  each (fig.1). On the handle there is a sliding knob attached to two springs which in turn are attached to the mounts of the prisms. The spring transfers linear movement into a rotary one with the individual prisms moving in opposite directions. The observer holds the instrument in front of the squinting eye so that he sees the axis of the eye parallel to that of the other eye.

Later Edmond Landolt (1846-1926), a Swiss ophthalmologist, added a graduated scale so that the angle of squint could be read by the observer directly. This instrument is illustrated above. In 1912 Alfred Bielschowsky (1871-1940), a German ophthalmologist, had a rotary prism built for him by Carl Zeiss of Germany. In Germany the rotary prism was called the Herschel prism, while in France it was called the Crêtès prism!!

One of the best known instruments of this kind was introduced later by the American ophthalmologist Samuel Risley (1845-1920), Chief of Wills Eye Hospital in Philadelphia (fig.2). He exploited the rotary prism principle for use in an ordinary trial frame.

The instrument has two prisms each of 15° apical angle giving a total of 30°. The face of the prism holder is engraved with graduations around the circumference showing the prism dioptres of deviation just as in the Landolt adaptation.

Various instruments incorporating the rotary prism principle are currently in vogue to carry out vergence tests.

Reproduced/adapted from Br J Ophthalmol, Doubling up: two prisms, two names, two countries, R. Keeler, A.D. Singh, H.S. Dua, 94, 1419, Nov 1 2010 with permission from BMJ Publishing Group Ltd.

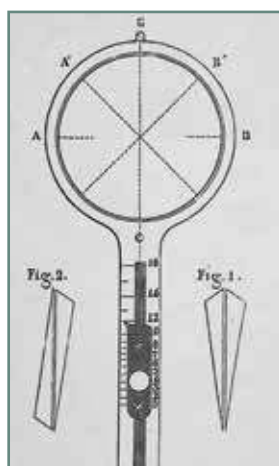

Fig.1 ► *Diagram of the Crêtès rotating prism*



Fig.2 ► *Risley's rotating prism, which can be inserted in the slot of a trial frame*

## SMOKY SOLUTION TO PRESSURE PROBLEMS: FICK'S OPHTHALMOTONOMETER



That raised eye pressure can damage the eye and affect vision was known long before a method to measure eye pressure was devised. The first attempt to measure the intraocular pressure was by Albrecht von Graefe in 1862. In 1857 he had introduced the "Iridectomy" operation, the first effective surgical treatment of glaucoma, for the relief of pressure in the eye and wanted to determine the pre- and post-operative eye pressure measurements to assess the effect of his operations. His experimental impression tonometer was not a success nor were a number of subsequent instruments designed by Frans Donders who was the first to use the term ophthalmotonometer in 1863. Hermann Snellen, Henri Dor and others were also unsuccessful. The first impression tonometer for general use, which worked by indenting a part of the globe, was invented by Hjalmar Schiøtz in 1905. In 1888, Adolf Fick introduced a tonometer that used a spring action with a flat plate applied to the temporal sclera (fig.1). The pressure in the spring varied according to the applanation of the plate. Apart from the inherent inaccuracies of this method the observer had difficulty in

knowing when the plate was applanated on the sclera. F. Oswald, a French ophthalmologist, recognised the difficulty of viewing the plate at the same time as reading the deflection on the scale. He devised a rather unusual solution comprised of a triangular shaped piece of glass that was smoked and placed behind a scraper, which was attached to the lever extending from the plate (fig.2). When applanation had been achieved a thin line was scratched into the smoke deposit on the glass terminating at a point in line with the pressure marked on the scale. The instrument shown above illustrates this modified Fick's tonometer. The instrument was made by Charles Verdin of Paris.

Adolf Fick (1829-1901) was a physiologist, born in Kassel and is perhaps best known for Fick's Law for the diffusion of matter, proposed in 1855. He held the Chair of Physiology at the University of Zurich in 1856 and then moved to Wurzburg where he held the Chair of Physiology until 1898. He is not to be confused with his nephew of the same name, Adolf Eugen Fick, who invented the contact lens. The name Fick (the uncle Fick but



referenced as Fick RA in some publications)<sup>1,2</sup>, is also intimately tied in with the "Imbert-Fick law" which states that "the pressure (T) inside a sphere filled with liquid and surrounded by an infinitely thin membrane can be measured by the counter pressure (P) which just flattens the membrane. The law presupposes that the membrane is without rigidity and elasticity:  $T=P/A$  (A is a constant)<sup>3</sup>". It is contended that

this is not really a "law" but was "invented by Hans Goldmann (1899-1991) to give his newly marketed tonometer (with the help of the Haag-Streit Company) a quasi scientific basis; it is mentioned in the ophthalmic and optometric literature, but not in any books of physics"<sup>3,4</sup>.

Reproduced/adapted from Br J Ophthalmol, Smoky solution to pressure problems: Fick's Ophthalmotonometer, R. Keeler, A.D. Singh, H.S. Dua, 95, 36, Jan 1 2011 with permission from BMJ Publishing Group Ltd.

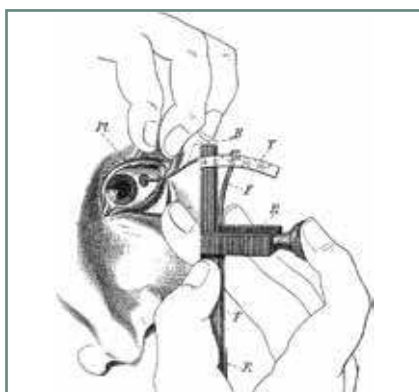

Fig.1 ► *The Fick ophthalmotonometer which was used to applanate the sclera to measure IOP*



Fig.2 ► *The Fick Oswalt ophthalmotonometer where a smoked glass plate was incorporated to facilitate reading of the pressure value*

1. Fick RA. Ein neues ophthalmotonometer. Verhandlungen der Physikalisch-Medizinische Gesellschaft Zu Wu'rzburg 1888;22:151.  
 2. Stuckey GC. Application of physical principles in the development of tonometry. Clinical Exp Ophthalmol 2004;32:633-6.  
 3. Markiewitz HH. The so-called Imbert-Fick Law. AMA Arch Ophthalmol 1960;64:189-59.  
 4. [http://en.wikipedia.org/wiki/Imbert-Fick\\_law](http://en.wikipedia.org/wiki/Imbert-Fick_law) (accessed 16 Nov 2010).

## THE 150<sup>TH</sup> ANNIVERSARY OF THE BINOCULAR INDIRECT OPHTHALMOSCOPE (1861-2011)



Eighteen hundred and fifty-one, the year in which Hermann von Helmholtz introduced his ophthalmoscope, can be regarded as the dawn of modern ophthalmology. A decade later, the binocular form of this instrument appeared on the scene. Invented by Marc-Antoine Giraud-Teulon (1816-1887; fig.1) the first model was made by Nachet of Paris and consisted of two solid rhomboid prisms placed in a metal carrier with a perforated concave mirror mounted on the front of the instrument. The instrument was hand-held with the other hand holding a condensing lens to form the virtual, reversed image for the indirect method of ophthalmoscopy. Illumination, directed via the concave mirror into the patient's eye, was from an oil lamp positioned above the patient's head.

The instrument was difficult to use, because of the low level of illumination and in this first model, the fixed inter-pupillary distance setting. The latter problem was solved in Giraud-Teulon's second model in which the right hand prism was divided, the end section moving in and out with a handle on a screw thread thus providing a range of inter-pupillary settings. A sliding mechanism

provided prisms behind the eyepieces to aid fusion. In 1862 John Zachariah Laurence, founder of the South London Ophthalmic Hospital, joined up with Charles Heisch to produce a more sophisticated instrument with variable interpupillary and vergence adjustments.

Despite the endorsement of Professor Hermann Knapp, these binocular ophthalmoscopes did not prove popular. Lack of adequate illumination, difficulty in co-ordinating the angle of illumination, binocularity and maintaining the patient's fixation were too tedious difficulties for most practitioners to surmount. Besides, these were early days in ophthalmoscopy and knowledge of the retina was still limited. However, both Giraud-Teulon and Laurence were undaunted in their pursuit and continued to modify their instruments. Giraud-Teulon had constructed a model with built-in magnification using the Galilean telescope principle. A pair of high minus lenses was placed behind the eyepieces and plus lenses behind the concave mirror.

In 1867 Laurence tried an altogether different approach. He interposed a thick concavo-

convex lens of high power in place of the usual condensing lens, tilting it at such an angle that the light from a lamp placed at the side was deflected into the patient's eye. The fundus was then examined binocularly. In 1872 Adolf Coccius, one of the early pioneers of ophthalmoscopes, introduced at the 4<sup>th</sup> International Congress of Ophthalmology in London a short focus opera glass with a plus 12 lens mounted behind the aperture of the perforated concave mirror. He called it an ophthalmoscope with "ampliation".

A year before his death in 1887, Giraud-Teulon incorporated a lamp into his instrument, the first attempt at a self-illuminating ophthalmoscope. However, at that time, the technology related to incandescent lamps was fairly rudimentary with poor output and short life. Thus Giraud-Teulon's effort was doomed to failure. The use of hand-held binocular indirect ophthalmoscopes in the last two decades of the 19<sup>th</sup> century was infrequent. The next significant instrument, in 1901, was Walter Thorner's reflex-free binocular ophthalmoscope on stand made by Ernst Busch of Rathenow. This instrument was eclipsed in 1911 when Carl Zeiss in collaboration with Allvar Gullstrand produced a more practical hand-held reflex-free binocular ophthalmoscope that could also be table mounted. By this time bulbs were more reliable and brighter. This instrument was followed the next year by the Zeiss-Gullstrand large reflex-free binocular ophthalmoscope on stand. This was the first commercially successful instrument for examining the retina binocularly.

Eleven years later in 1923, Otto Henker, the chief optical designer at Carl Zeiss collaborated with Gullstrand to produce the large simplified reflex-free binocular ophthalmoscope, which became popular partly because it could also be adapted as a refractometer. In 1928, Thorner with the Busch Company produced his own reflex-free binocular ophthalmoscope, which could be hand-held or stand mounted.

The biggest breakthrough in binocular indirect ophthalmoscopy came in 1944 while Charles Schepens was a Lang Scholar at Moorfields Eye Hospital. He managed to collect pieces of metal, bulbs and lenses from the bombed out shell of the basement of the hospital badly damaged by a doodlebug in July. From these components he put together a prototype (fig.2);

the forerunner of the first head-worn binocular indirect ophthalmoscope, which he presented at the Belgian Ophthalmological Meeting in 1945. In 1957, under the guidance of Sir Stewart Duke-Elder, then the most influential ophthalmologist in the UK, a young Lorimer Fison travelled to Boston to the Schepens Institute. It is unlikely that either of them foresaw the resultant revolution in retinal examination and surgery. Having used the Schepens ophthalmoscope while in Boston, on his return Fison envisaged an improved instrument and collaborated with Charles Keeler in this endeavour.

The Fison Binocular Ophthalmoscope (fig.3) was first unveiled in April 1959. At first it was perceived as a specialised instrument belonging only to the hands of those specialising in retinal surgery. Gradually, however, this concept changed and it came to be regarded as an essential instrument for every ophthalmologist. Its success was due to three factors: simplicity, robustness and the fact that by means of a semi-silvered mirror attachment it was possible for a second observer to see the same image as the user, thereby opening up a completely new and much superior way of teaching retinal diagnosis and surgery.

One of the design features was the critical angulation of the viewing mirrors so that diplopia never was a problem, provided the optics were correctly adjusted. Maintenance of the correct angulation despite heavy hospital use was achieved by use of a metal baseplate, which acted as a solid optical bench. Powerful illumination from an 18 W lamp ensured that virtually every retina could be visualised.

Most of the binocular indirect ophthalmoscopes (BIOs) that followed owed much to one or other of these first instruments and several of them did make worthwhile improvements. These included efforts to design BIOs that enabled visualisation through undilated pupils; that could record the retinal image; that were small enough to be spectacle mounted (fig.4); that were delivery systems for therapeutic laser treatments and ones that did not need an electrical cable.

The first small-pupil head-mounted indirect was described by Oleg Pomerantzeff in 1968. This embodied the Gullstrand principle by means

of complex movements of the beam-splitting and viewing mirrors but it required several adjustments to prepare it for use. Consequently it never enjoyed the popularity it deserved.

Capturing a good quality retinal image through a BIO remained the holy grail for both designers and users for many years and it was not until CCD cameras became small enough to be incorporated into the ophthalmoscope that this could reliably be achieved, requiring repeated attempts by several manufacturers.

Miniaturisation has long been seen as a means of advancing a device and BIOs are no exception. Clearly, reduction in size and weight would be advantageous and there were many who preferred their instrument to be spectacle mounted rather than on a headband. This innovation was first embodied in the Schultz Crock instrument made by SOLA of Australia. It weighed only about 115 g and had no moving parts. Several other manufacturers followed with spectacle BIOs of their own.

Laser indirects are outside the scope of this short historical review but nonetheless mention should be made of Dr Mizuno of Tokyo who collaborated

with the Nidek Company in the development of the first such instrument, described in the British Journal of Ophthalmology in 1981. This enabled a whole new way of treating a number of retinal conditions, particularly retinopathy of prematurity.

Often the simplest ideas are the best and one of these was to remove the electrical connection from the BIO. Zeiss were the first to attempt this in the 1980s but it was not until the miniaturisation of lithium ion batteries that Keeler was able to produce the first successful wireless unit. The German manufacturer Heine produced their version a few years later.

While there have been numerous advances and a few novelties, the giants of the past century remain Schepens and following him Fison, as none of these advances would have been possible without them.

Reproduced/adapted from Br J Ophthalmol, The 150th anniversary of the binocular indirect ophthalmoscope: 1861-2011, R. Keeler, C. Burrows, A.D. Singh, H.S. Dua, 95, 306-307, Mar 1 2011 with permission from BMJ Publishing Group Ltd.



Fig.1 ▶ *Marc-Antoine Giraud-Teulon (1816-1887) who invented the first version of the binocular ophthalmoscope*



Fig.2 ▶ *Dr Charles Schepens with his original prototype and the small pupil ophthalmoscope*



Fig.2 ▶ *The first Fison binocular indirect ophthalmoscope*



Fig.4 ▶ *Schultz Crock spectacle indirect ophthalmoscope*

# RYLAND SCHEMATIC EYE: A SCHEME TO LEARN



Fig.1 ► Painted shells, representing a range of retinal conditions



Fig.2 ► A similar practice eye is Dunn's Model Eye

This instrument, first advertised in 1910, was one of a number of artificial eyes designed for practitioners on which to practice ophthalmoscopy and refractive skills.

The main black metal cylindrical body is the receptacle for different solid glass parts used for assessing four different refractive conditions, myopia, hypermetropia, emmetropia and astigmatism. This is achieved by inserting the glass component in the end of the tube. Each one has a spherical cornea with the exception of the one for astigmatism, which has a toric surface. The refractive index of the glass is chosen to approximate the principal and nodal points in their correct positions.

The base of each glass part is frosted to give a more realistic appearance to the retinal image. In addition, it makes it easier to see the variation in size of the retinal image when trial lenses are used.

Mounted on the front of the apparatus are two cells for trial lenses and a knob on top to adjust an iris diaphragm to simulate different pupil apertures. Painted shells, representing a range of retinal conditions (fig.1) are mounted behind the frosted base of the glass part. The schematic eye can be used for practicing ophthalmoscopy, keratometry, retinoscopy and ophthalmometry. The instrument, patented in 1906, is named after Herbert S Ryland who co-invented it with Stephen Chalmers while working at the Northampton Institution (Polytechnic). The instrument is also known as the Hu-Modell Eye.

A similar practice eye is Dunn's Model Eye (fig.2) manufactured by F Davidson & Co, London. This instrument includes correcting lenses and a lens cell with axis marking for cylinders. Instead of a diaphragm there is a disc with three apertures.

This image was provided to the Br J Ophthalmology by courtesy of Richard Keeler and published on Cover of BJO June 2014. It is reproduced here.

## EMPOWERING EYES: THE THORNER OPTOMETER



The image above is of an instrument called an optometer, also known as an eye refractometer, which measures the dioptric power of the eye. This instrument was designed by Professor Walter Thorner (fig.1) in the 1920s. It was made by the Emil Busch Company of Rathenow, Germany. The company was founded in 1801 and eventually merged with the Carl Zeiss Foundation in 1931, today one of the leaders in the manufacture of precision optical instruments.

While studying as a medical student in Berlin, Thorner expressed annoyance at the bright light reflecting back from the cornea (light reflexes) making fundus examination with the ophthalmoscope difficult. He set out to address this issue and in his thesis of 1896 he reported a solution to the problem using up-to-date technical facilities at his disposal. Two years later he became the first individual, not Allvar Gullstrand as often cited, to establish the principle of reflex-free ophthalmoscopy. The reflex-free principle was simple (fig.2). The pupil of the eye was divided in two halves. Through one half the light was projected into the eye to

illuminate it and through the other half, the fundus was viewed. The device incorporating this facility was a stand mounted ophthalmoscope made by Schmidt and Haensch. Unfortunately the instrument was not successful but Gullstrand's, which came a little later, was and became the predominant market leader.

Many years later Walter Thorner worked on refractometry and established a connection with the Emil Busch Company, which constructed for him 'The Thorner,' an Optometer which he patented in 1922 (fig.3). This optometer or refractometer became very popular with more than 2500 instruments being sold between its introduction and 1944 when the company ceased production.

The operation of the optometer was simple. A thin strip of light produced by the filament of a bulb was focused on the macular area of the retina. The instrument measured objectively the ametropia (refractive power) of the eye and any astigmatism including its meridian.

At the beginning of the century Thorner, like

others, was striving to record the fundus on film but his results were poor. One of his rivals was Frederick Dimmer who was working with the Carl Zeiss Company. By 1908 Dimmer had produced exceptional black and white images which were published in an atlas. Thorner was so impressed that he wrongly accused Dimmer, of "touching up" the results. Thorner however

took comfort in the knowledge that only one instrument, the size of a small car, could take these photographs and the instrument could not be commercialised. Since Thorner's pioneering work on the Optometer many versions have been produced over the years.

Reproduced/adapted from Br J Ophthalmol, Empowering eyes: the Thorner Optometer, R. Keeler, A.D. Singh, H.S. Dua, 95, 925, Jul 1 2011 with permission from BMJ Publishing Group Ltd.



Fig.1 ► Professor Walter Thorner

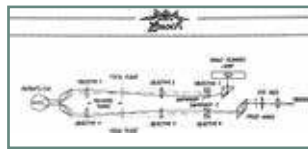

Fig.2 ► Ray diagram illustrating the "reflex-free" principle

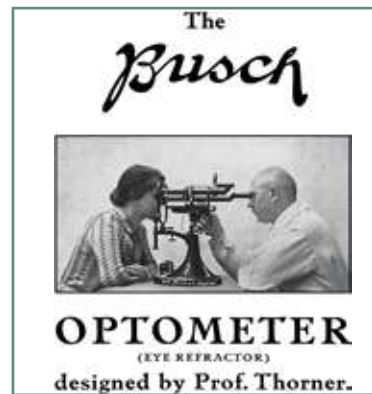

Fig.3 ► Measuring the dioptric power of the eye of a patient (left) by an observer using Thorner's optometer

# SUCTION EXTRACTION: TAKING A GRIP ON INTRACAPSULAR CATARACT EXTRACTION WITH THE ERISIPHAKE



The word cataract is derived from the Greek word "kataraktes", which refers to something that gushes or swoops down like a waterfall. How it came to be used to describe the opacification of the crystalline lens in the eye is not clear. Though cataract, as a condition that impairs vision was known since time immemorial, its first rational treatment was offered by the ancient Indian surgeon Sushruta (~2600 BC), in the operation of "couching" wherein the opaque lens was dislocated posteriorly to fall in the vitreous cavity, with a fine instrument inserted into the eye. This procedure is widely depicted in ancient Indian and Egyptian art.

Modern cataract surgery began around 1747, when Jacques Daviel introduced the extracapsular method of extraction of the lens<sup>1</sup>. This was a major advance but had limitations which included intraocular remnants of lens cortex and opacification of the capsule left behind. The next advance was the "intra-capsular" method of extraction of the whole intact lens. A Frenchman, Charles de Saint-Yves (1667-1733), is credited with the first such

operation. Henry 'Jullundur' Smith, an Irishman working in the North Indian cities of Jullundur and Amritsar, devised a method of "Extraction of Cataract in the Capsule," which later became known as the "pressure counter-pressure method" or the "Smith Indian method." This gained popularity and was the preferred method for several decades<sup>2</sup>.

The two challenges faced by cataract surgeons were to develop a safe method of gripping the lens without rupturing it and to find a technique to break the zonules which held the lens in its natural position. The zonules were particularly strong in the 'immature' cataracts compared with the more ripe "mature" cataracts. The advent of enzymatic digestion of the zonules with a chymotrypsin was later to answer the latter challenge. Other methods to grip the lens capsule and pull, rather than push, the lens out were developed. The Arruga's forceps was one such popular method. Another popular method was the suction cup, which could grasp a larger area of the capsule and thus posed less risk of capsule tear.



The Dimitry instrument was one of a number of "suction" methods of gripping the lens capsule. The instrument was first introduced by Dr Theodore J Dimitry of New Orleans in 1933 and was referred to as a vacuum grasper. The instrument illustrated above was a later model introduced in 1939. It consisted of a glass syringe to which was attached, via a Luer lock, a needle made of platinum with a 4 mm diameter gold plated cup. The face of the cup was flat. A close-fitting plunger with spring was introduced into the syringe and, by withdrawing the handle of the plunger, created a negative pressure in the cup which in turn grasped the lens capsule by suction, when applied to it as the vacuum was created.

Similar devices using motors to generate suction were in vogue<sup>3</sup>. Dimitry's aim was to simplify the procedure and eliminate the cumbersome tubing of motorised units. This instrument made by V Mueller of Chicago was also comparatively inexpensive.

The first "pneumatic forceps" was invented by W Stoewers in 1902, and fig.1 shows his model compared with a much later erisiphake illustrated in the John Weiss catalogue of 1958. With time, more designs emerged, and no less than 10 very similar devices are shown in the Storz catalogue of 1977.

VH Hulen of Houston, often quoted as the first to use a suction instrument to grasp the lens for intracapsular extraction, announced his instrument's success in six operations in the Ophthalmic Record in 1910. He used a stirrup pump to create a negative pressure in a large wicker-covered jar. Control of the pressure was assigned to a nurse whose job was to gradually open the valve. In a later model, the valve was incorporated in the handle. The vacuum cup was 5 mm in diameter and 2 mm deep (fig.2).

Ignacio Barraquer's "Erisiphake," first introduced in 1917, included a pneumatic machine which produced a vibratory vacuum to enable the fibres of the zonule to be broken without due force (fig.3). Numerous variations of the Erisiphake were introduced over the next 50 years (fig.4). Intracapsular cataract extraction prevailed for over 60 years, and then, as it is not unusual in medicine, history came full circle. With advances in microsurgery and the invention of the operating microscope, extracapsular extraction became popular once again and replaced the intracapsular technique. A reduced incidence of retinal detachment and capsular support for the prosthetic intraocular lens implant are two important reasons for which the extracapsular principle remains the preferred choice to this day.

Reproduced/adapted from Br J Ophthalmol, Suction extraction: taking a grip on intracapsular cataract extraction with the erisiphake, R. Keeler, A.D. Singh, H.S. Dua, 95, 1211-1212, Sep 1 2011 with permission from BMJ Publishing Group Ltd



Fig.1 ▶ Stoewers Erisiphake



Fig.2 ▶ Hulen Erisiphac

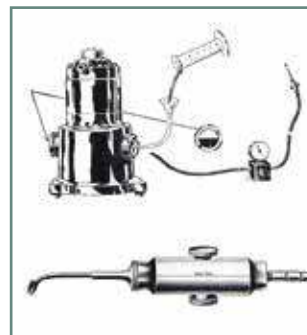

Fig.3 ▶ Barraquer Erisiphake



Fig.4 ▶ Simple Erisiphake

1. Kelman CD, Kwitko ML. The History of Modern Cataract Surgery. New York: Kugler Publications, 1998.

2. Ravin JG. Henry 'Jullundur' Smith's 'extraction of cataract in the capsule'. Arch Ophthalmol 2005;123:544e5. <http://www.archophthalmol.com> (accessed 9 Jul 2011).

3. Barraquer I. Discussion on the intracapsular method of cataract extraction. BMJ 1924;11:660e1.

## CUT IT, BURN IT, LYSE IT: ZIEGLER'S ELECTROLYSIS AND CAUTERY SET



The word "cautery" has its origin in Latin, referring to a branding iron, and in Greek in which a similar word denoted the act of burning. In medicine, "cautery" refers to the use of an agent or instrument that destroys tissue by burning or searing<sup>1</sup>. The tissue could be normal or abnormal and the nature of the agent could be instruments capable of transferring high heat or freezing cold ; chemical substances, electric currents or lasers.

The use of heat and chemicals to induce scarring in tissue has been known since ancient times. Electric scarring of tissue came later. The use of electric currents to remove eye lashes by the process of "electrolysis" has been in vogue since 1873.

Dr Samuel Lewis Ziegler (fig.1) 1861-1926, was one of the earliest advocates of electricity in ocular therapeutics. He was a prolific author and inventor. Of his many inventions he is best remembered for his cystitome (fig.2, A56). Other inventions included an iridotomy knife with which he pioneered his V-shaped incision, lachrymal probes, curettes, dilators (fig.3), a lid everter

and a vectis (fig.2, A60). In 1914, in conjunction with the De Zeng Company, he designed an ophthalmoscope with several new features. His last instrument, which he developed while in London in 1925 just before he died, was an ingenious syringe for washing out the anterior chamber.

The set of electrodes with handle shown here were the design of Samuel Lewis Ziegler and were made by the Keystone Electric Co. of Philadelphia, Pennsylvania, USA. Dr Ziegler published a paper in the transactions section of Ophthalmology of the AMA in June 1909 on "Galvanocautery puncture in ectropion and entropia". The set would have been in production by then and the instrument was in all probability used in the operation he described and is still referred to in modern literature.

Ziegler graduated from the medical department of the University of Pennsylvania in 1885 and entered Wills Hospital as an intern for 2 years, and was immediately appointed assistant surgeon in 1887. In 1901 he was elected attending surgeon at Wills, where he stayed until his resignation in

1916. He was on many committees to do with health services in Philadelphia and was president of the College of Physicians, Philadelphia, 1915-16. He was a member of numerous international ophthalmic organisations.

He was planning a large body of work on surgery of the eye but he died before this could be achieved. According to a close friend

he had accumulated an enormous amount of material including his own drawings of surgical procedures. His account of the early pioneers in ophthalmology would have provided a rich source of reference for historians but this was one piece of history that was not to be.

Reproduced/adapted from Br J Ophthalmol, Cut it, burn it, lyse it: Ziegler's electrolysis and cautery set, R. Keeler, A.D. Singh, H.S. Dua, 95, 1530, Nov 1 2011 with permission from BMJ Publishing Group Ltd.



Fig.1 ▶ Samuel Lewis Ziegler, 1861-1926



Fig.2 ▶ Ziegler cystitomes A52-56 and barbed vectis A60

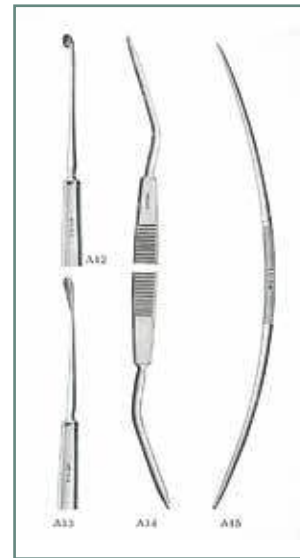

Fig.3 ▶ Ziegler lachrymal and meibonian curettes and dilators

1. <http://www.thefreedictionary.com/cautery> (accessed 19 Sep 2011).

## REDUCING ERRORS IN MEASURING REFRACTIVE ERRORS: DE ZENG REFRACTOMETER



Thomas Young's optometer, invented in 1800, was the first in a long line of instruments designed to measure the refractive errors of the eye. In 1895, Henry L De Zeng Jnr patented his refractometer (fig.1). This was to be the first of 40 other inventions he patented between 1895 and 1925.

His refractometer was an advance on the others that prevailed at the time, in both ease of use and accuracy in measuring the refractive state of the eye. Another advantage was that the instrument did not require the pupil to be dilated prior to measuring the refractive error. The instrument consisted of a nickel-plated brass tube on a cast iron stand. The tube carried a lens inside, which the patient could move to focus a test target placed 15-20 feet away. Astigmatism was calculated by the use of two rotatable lens wheels in which the cylindrical lens could be turned around its axis.

The refractometer, depicted above was made in 1898 by the Cataract Tool and Optical Company of Buffalo, New York, which later became the Hardinge Machine Company. Henry L De Zeng

Jnr (1866-1929) (fig.2) was one of the most prolific inventors of ophthalmic and ENT instruments in the first quarter of the 20<sup>th</sup> century. He was a direct descendant of Baron Frederick A De Zeng (1753-1837) of Dresden, Saxony, who was an important local dignitary and an early settler in Geneva, New York, where he established a coloured glass manufacturing factory.

In 1885 Henry (known as Harry) De Zeng Jnr joined the Standard Optical Company and later attended Hobart College and in 1890 qualified in medicine in Chicago. During this time he took a course in refraction and optics. In 1893 he became interested in diagnostic equipment and started inventing an impressive line of optical and medical instruments of which this refractometer was the first.

He is credited with developing the first practical electric ophthalmoscope in 1905, and in 1915 the first battery handled ophthalmoscope using Dr GS Crampton's newly invented use of batteries. Until his invention of a cover plate to hold lenses in the Rekoss disc, each small lens had to be individually cemented into a recessed holder, a

time-consuming process. Henry De Zeng today is best known for his series of early phoropters which were made by his own company, De Zeng Standard Company, which he set up in 1906. He also developed many of the machines to make his instruments.

In 1924 he retired and the following year sold his business to the American Optical Company for \$1.5 million. He served as a director of that company until his death in 1929.

Reproduced/adapted from Br J Ophthalmol, Reducing errors in measuring refractive errors: De Zeng refractometer, R. Keeler, A.D. Singh, H.S. Dua, 96, 311, Mar 1 2012 with permission from BMJ Publishing Group Ltd.

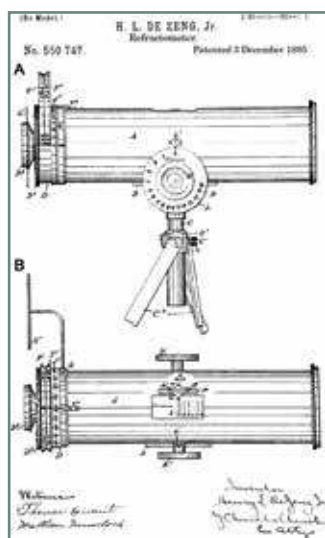

Fig.1 ▶ Drawings of the refractometer for the patent



Fig.2 ▶ Henry L De Zeng (1866-1929)

## TESTING VISION CAN BE TESTING: WORTH'S IVORY-BALL TEST



Testing vision in children can be a challenge, the younger the child the more challenging the task. Often more than one test has to be performed on more than one occasion to get a reasonable grasp on the child's vision. There are several different tests in vogue, some more suited for certain age groups than others<sup>1</sup>. In 1896 Claud Worth introduced the "ivory-ball test", which could be used for testing vision in children who are old enough to walk, usually between the ages of 1 and 3 years. It consists of a set of five ivory balls varying in size from 0.5 ins to 2.5 ins. The child, with both eyes open, is encouraged to handle the balls. One eye is then covered. The ball is thrown with a spin so that it moves in a different direction to where it appears to have been thrown. The child is asked to go and pick up the balls as each is thrown approximately 18 ft beginning with the largest. As Worth states "It is easy to tell, by the way in which the child runs for the ball, whether he really sees it before he starts or is only going to look for it." "Children are always ready to play this ball game", commented Worth. It is at best an approximate estimate of a child's visual acuity.

Worth also recommended this test as a means of convincing parents that their child with amblyopia has poor vision in one eye. A demonstration of the test being performed by each eye in turn helped remove any scepticism the parents may have had about poor vision in their child's eye and be more inclined to enforce "patching".

Use of ivory to make billiard cue balls was common around the time Worth developed the ivory balls for his vision test<sup>2</sup>. The industrial use of plastics was in its infancy and one can assume that ivory was therefore the preferred material. The use of ivory would now be frowned upon and is illegal in many countries.

Claud Alley Worth (1869-1936) (fig.1) qualified at St Barts Hospital in 1893 and then studied ophthalmology at the same hospital. In 1906 he was elected to the honorary staff at Moorfields Eye Hospital, London, where he duly became a consulting surgeon. He attained international fame for his pioneering and definitive book entitled 'Squint, its causes, pathology and treatment' published in 1903 (fig.2). It was translated

into many languages and reached its 6<sup>th</sup> edition in 1935.

Worth co-wrote with Charles May another book called "A manual of diseases of the eye" in 1906. He contributed to many papers on the transaction of the Ophthalmic Society of the UK and was a prolific inventor of instruments, the best known being his amblyoscope.

Worth could just as easily have been a household name in the world of yachting. He became president of the Little Ship Club and vice commodore of the Royal Cruising Club, a master mariner and first class pilot. He wrote about his experiences in 1910 with "Yacht cruising" and later "Yacht navigation and voyaging".

Reproduced/adapted from Br J Ophthalmol, Testing vision can be testing: Worth's ivory-ball test, R. Keeler, A.D. Singh, H.S. Dua, 96, 633, May 1 2012 with permission from BMJ Publishing Group Ltd.



Fig.1 ► *Claud Worth (1869-1936)*

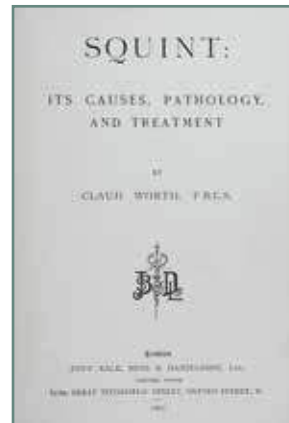
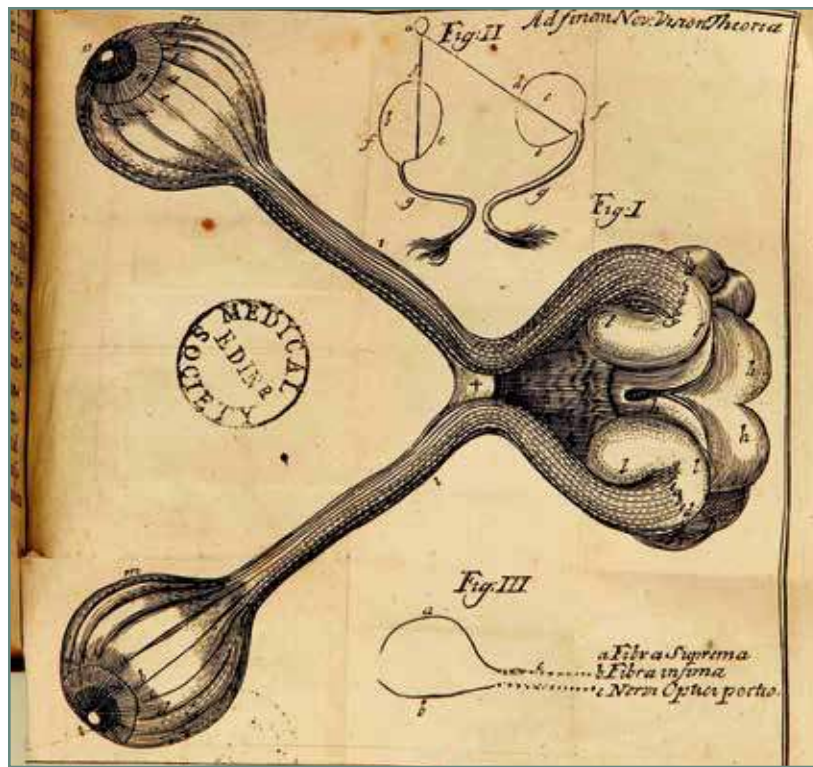

Fig.2 ► *Worth's landmark book on squint*

1. Balachandran A. Visual assessment in children. March 2005. [http://www.ksos.in/ksosjournal/journalsub/Journal\\_Article\\_1\\_5.pdf](http://www.ksos.in/ksosjournal/journalsub/Journal_Article_1_5.pdf) (accessed 16 Mar 2012).  
2. Ask Jeeves Encyclopaedia. Billiard ball. [http://uk.ask.com/wiki/Billiard\\_ball](http://uk.ask.com/wiki/Billiard_ball) (accessed 16 Mar 2012).

# THE GREAT AND THE WRONG: DR WILLIAM BRIGGS



Dr William Briggs (fig.1) was a 17<sup>th</sup> century physician with the distinction of being one of the first to specialise in ophthalmology. Despite competition with established quacks and charlatans such as the illiterates Sir William Read and Roger Grant, he established a reputation as an honest ophthalmic physician and made some significant contributions to the subject.

He was born in Norwich in 1650. At the age of 13 he was admitted to Corpus Christi College, Cambridge, where he obtained his BA, MA and his MD in 1677. He was made a Fellow of the College, a position he held from 1668 to 1682. He pursued further studies at Montpellier under Raymond Vieussens, an expert in the anatomy of the brain, which influenced him to pursue his special interest in the anatomy of the visual system on his return to Cambridge, England.

The landmark feature of his studies was the publication of his *Ophthalmographia* in 1676. Later editions of this important book were bound with his work on visual physiology, *Nova Visionis Theoria* (New Theory of Vision) (fig.2). These editions, first published in English in

two parts in 1681 and 1683, were prefaced by Sir Isaac Newton, then Lucasian Professor of Mathematics at Trinity College, Cambridge, who paid tribute to Briggs by acknowledging that he had learnt much from him about the physiology of the eye for his book entitled *Opticks*. Newton was a contemporary and friend of Briggs at Cambridge and spent much time watching him exercise his great skill as a dissector.

Briggs described the papillae of the optic nerves (in a macroscopic postmortem description of the optic discs) and established that the retinal nerve fibres converged to the papillae (fig.3). He gave the analogy of a spider in its web to describe the mechanism of vision. He suggested that just as vibrations generated in the peripheral strands of a spider's web travel to the centre, so rays of light strike the fibres in the retina and the vibration is transmitted to the papilla and conveyed to the nerve.<sup>1</sup> He did not consider that decussation of fibres occurred at the optic chiasma main image above. Briggs theory of vision was not universally accepted ; Hirschberg described it as "no theory at all." Newton also disagreed with Briggs.



The last phase of Briggs' career was his appointment as a specialist in ophthalmology at St Thomas' Hospital, London in 1683. He soon became widely known as the leading authority in, what was in effect, neuro-ophthalmology. His case reports on the subject were presented to the Royal Society and published in the Philosophical Transactions in 1684. He is usually credited with being the first to publish a case report of night blindness. William Briggs only served 7 years at St Thomas' before he was unjustly removed

by the invocation of an ancient writ politically motivated by King Charles II.

Little is known of Briggs' work thereafter although he was appointed Physician in Ordinary to King William III and a Censor (Examiner) at the College of Physicians. He died in 1704 at the age of 54 and was buried in the village where he lived in Kent.

Reproduced/adapted from Br J Ophthalmol, The great and the wrong: Dr William Briggs, R. Keeler, A. Dua, A.D. Singh, H.S. Dua, 96, 781-782, Jun 1 2012 with permission from BMJ Publishing Group Ltd.



Fig.1 ▶ Dr William Briggs (1650-1704)



Fig.2 ▶ William Briggs' important book entitled Nova Visionis Theoria

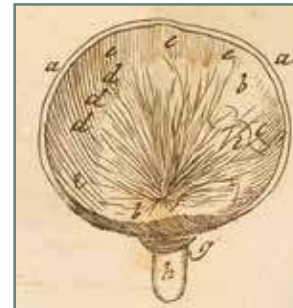

Fig.3 ▶ Briggs' depiction of the retinal nerve fibres converging to the papilla

## GOLDEN EYES



The medical profession is studded with individuals who have demonstrated talents beyond their professional expertise. Many international ophthalmology conferences have thrown up pleasant surprises wherein music, songs, paintings, photographs and literature, all composed and/or performed by ophthalmologists, have been put on display, much to the delight of compatriots in the audience. Medical practitioners are also no strangers to sport. In the 2012 Olympics in London, British ophthalmology boasted of one Hyla Bristow (Henry) Stallard (1901-1973) (fig.1) who won the bronze medal at the 1924 Olympic Games held in Paris. The obverse and reverse of the medal are depicted above.

The story behind this medal is now part of Olympic legend. Henry Stallard had been picked to represent Great Britain in the 800 and 1500 m races. In the 800 m final, Stallard appeared to act as pacemaker for the eventual winner, his fellow countryman Douglas Lowe (who also went on to win gold in the 1928 Games). The following day, the press reported that Stallard had sacrificed

the possibility of winning a medal himself by his action. Stallard had run five races in 5 days when he lined up for the 1500 m final. At this point he was nursing a broken metatarsal bone in his right foot. He disregarded advice from the team doctor and, despite the handicap, competed with his foot held together with bandages, which did little to dampen the excruciating pain experienced as he ran. His third place behind the Finn, Paavo Nurmi (1897-1973) (fig.2), the greatest middle distance runner of his generation, was of heroic proportions.

Stallard collapsed at the tape and was unconscious for half an hour afterwards.

The 1924 Olympic Games was the subject of the award winning film *Chariots of Fire* in which Stallard featured. The bronze medal shows, on the obverse side, a naked victorious athlete helping his rival get to his feet. On the lower section can be seen the Olympic rings, the first time they had appeared on an Olympic medal.

On the reverse side of the medal is an arch of various sporting equipment representing both

summer and winter Olympics. the bottom left of the arch is a harp, which is the symbol of the cultural aspects of the games.

Henry Stallard's distinguished medical career began at St Bartholemew's Hospital as a clinical student. It was here that he decided to specialise in ophthalmology. At the age of 33 he became a consultant at both Barts and Moorfields, in London. During the Second World War he was put in charge of eye units in the Middle East. His experience in dealing with casualties from the western desert provoked his interest in plastic surgery. It was during this period that he first drafted his book *Eye Surgery*, which went into many editions. He drew all the illustrations for this classic himself.

Henry Stallard was not the only young ophthalmologist to represent Great Britain in the 1924 Olympic Games. Philip Geoffrey Doyne (1886-1959) (fig.3), son of Robert Doyne founder of the Oxford Ophthalmological Congress and the Oxford Eye Hospital, had already appeared in the Antwerp Games of 1920 in the fencing team. He repeated this in 1924, but failed to win a medal. Doyne was twice British foil champion. Doyne served for two and a half years in the Royal Army Medical Corps as an eye specialist in the Middle East and was also a consultant at Moorfields Eye Hospital. He took a special interest in children's eyes and was ophthalmic surgeon at the Hospital for Sick Children, Great Ormond Street. In 1943 he was elected Master of the Oxford Congress, of which his father had been first Master.

Reproduced/adapted from Br J Ophthalmol, Golden eyes, R. Keeler, A.D. Singh, H.S. Dua, 96, 925-926, Jul 1 2012 with permission from BMJ Publishing Group Ltd.



Fig.1 ▶ Henry Stallard (1901-1973)

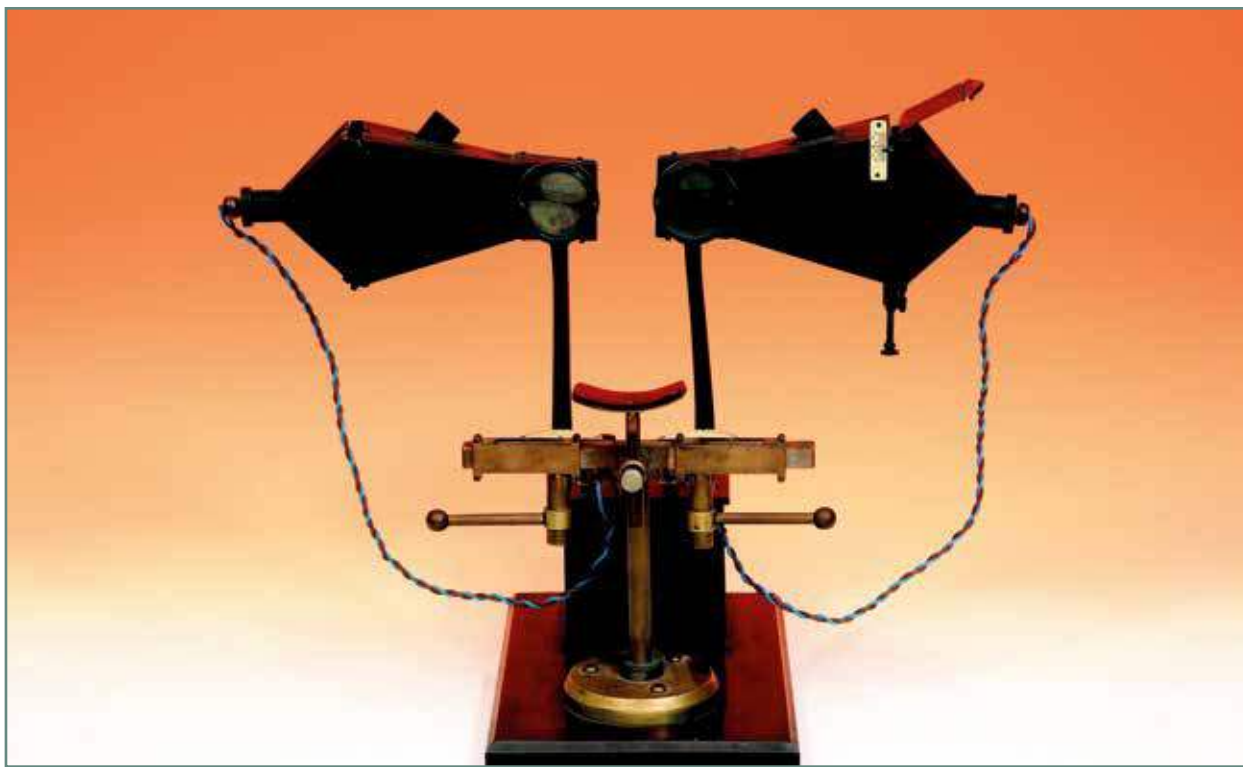

Fig.2 ▶ Paavo Johannes Nurmi (1897-1973)



Fig.3 ▶ Philip Geoffrey Doyne (1886-1959)

## SCOPING STRABISMUS: STAND-MOUNTED SYNOPTISCOPE



Strabismus or squint has been a social stigma since time immemorial, its cosmetic effect being more a concern to those afflicted by it than any visual impairment caused. The history of the attempts at measuring the effect of strabismus on vision is linked to the invention of the "stereoscope", an instrument used for viewing objects binocularly.

The first stereoscope was invented by Sir Charles Wheatstone, a British inventor, in 1835. Early stereoscopes used hand-drawn images as photography had not been invented yet. Shortly afterwards in 1843 Sir David Brewster produced his lenticular stereoscope. It was using this format that Emil Javal laid down the foundation of the method of treatment for squint in his famous book on strabismus.

In 1861 Oliver Wendell Holmes, while still a student at Harvard, invented the hand-held stereoscope (fig.1) which was commonly used in many households around the world for viewing pairs of photographs of scenery, buildings and people in three dimensions (3D). As a means of entertainment and viewing images in 3D,

it was a very popular instrument<sup>1</sup>. This same instrument and its many variations was used as a training tool for patients with squint. In latter day stereoscopes, stereo images were used. These consisted of two images of the same object taken with two lenses spaced by the distance between the two pupils (approximately 2.5 inches). A prism-lens in the viewfinder of the stereoscope allows the two images to blend into one 3D image as perceived by the brain.

In 1891 Priestley Smith of Birmingham had identified the use of a simple instrument consisting of two independent "fusion tubes" and later the "heteroscope", in which the two tubes were connected horizontally for easier use. Later Claud Worth introduced his amblyoscope in 1895, based on similar principles.

The instrument above is a "synoptoscope" designed by Dr William Ettles in 1912-13. The production model had to wait until 1922 to be manufactured, some 4 years after Ettles' death in 1918. Dick Howard was a dispensing optician in London who had worked with Dr Ettles on the original synoptoscope prototype. He later joined

the firm, Curry and Paxton, which made the original commercial models under his direction. It may be of interest to learn that one of the first people to acquire one of these instruments was Dr Ernest Maddox in 1925.

The synoptoscope more often referred to as a synoptophore was used for the assessment and training of patients with squint. Ettles gave it the name synoptoscope (syn-together, scope-aim) to convey accurately the use of the instrument... "with the aim or purpose of bringing the eyes together".

Ettles had produced this instrument to overcome the mechanical limitations of the widely used Worth's amblyoscope. He introduced an adjustable interpupillary setting and a horizontal angling of the tubes around the centre of

rotation of the eye. The early models used bulbs connected to a battery to illuminate the slides. Although this was not the first "amblyoscope" to be mounted on a stand for greater stability (that innovation goes to Maitland Ramsay of Glasgow in 1905, fig.2), it was the first fully adjustable instrument and the precursor of many designs of synoptophore to follow in the next 40 years.

Strabismus is also the name given to a protein in *Drosophila*<sup>2</sup>. Mutations in the strabismus gene result in altered development of ommatidia in the *Drosophila* eyes. Vertebrates too have strabismus-type proteins, and mutations in these are associated with neural tube defects, spina bifida and some forms of cancer in humans.

Reproduced/adapted from Br J Ophthalmol, Scoping strabismus: stand-mounted synoptoscope, R. Keeler, A.D. Singh, H.S. Dua, 96, 1051, Aug 1 2012 with permission from BMJ Publishing Group Ltd.



Fig.1 ► *Holmes stereoscope*  
(From *Eye and Instruments* by Isolde den Tonkelaar, Harold Henkes and Gijsbert van Leersum. Batavian Lion 1996)

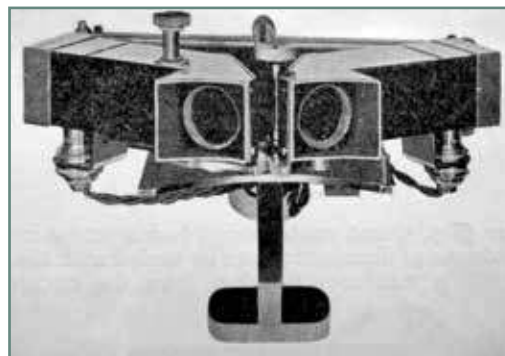

Fig.2 ► *Maitland Ramsay instrument*

1. <http://home.centurytel.net/s3dcor/history.htm> (accessed 16 Jun 2012).  
2. [http://en.wikipedia.org/wiki/Strabismus\\_\(protein\)](http://en.wikipedia.org/wiki/Strabismus_(protein)) (accessed 15 Jun 2012).

# THE ART OF SURGERY: SIR WILLIAM ADAMS (1783-1827)



This illustration is from Sir William Adams' book, "Practical observations on Ectropium or eversion of the eyelids with a description of the new operation for the cure of that disease" published in 1812. The book also includes a section "on the modes of forming an artificial pupil (fig.1) and on cataract omit".

The left eye, top and bottom, shows "David Crommie's Eye previous to the operation and a fortnight later". Likewise on the right top and bottom "Mr Menoe's Eye previous to the operation and after the disease was cured". One might be forgiven for suspecting that the artist was persuaded that anything less than a perfect result would not be tolerated. It was in the illustrator's (artist's) gift to deal with any blemishes left by the surgeon. Preoperative and postoperative images constitute useful and important records and have been presented as evidence of the change induced by treatment. Today, photographs provide considerable accuracy but equally Photoshop editing allows one to achieve what artists of yesteryears could by their artistic skills. Patient confidentiality did

not appear to be a major issue then. Even if the patient could not be identified from the image, the inclusion of the patient's name in the legend ensured non-confidentiality. Clearly we have come a long way in this regard.

To correct the ectropium and form a normal eye, Adams presented an innovative procedure using a narrow knife of his own design (fig.2). His method drew praise from a number of eminent surgeons. Adams was proud of what he considered to be his own method for the cure of ectropium but this had been foreseen and written about centuries before him. Hirschberg however conceded that the operation was probably original with Adams.

William Adams was a controversial figure for most of his professional life. He was born in Cornwall and had his early training there before going to London in 1806. A year after his studies at St Thomas' and Guy's Hospitals he was taken on as a student by John Cunningham Saunders at the London Infirmary for Curing the Eye and Ear (Moorfields Eye Hospital). He learnt much there including the treatment of those suffering

from Egyptian Ophthalmia. Saunders required Adams to pledge that he would not go into print on the details of the operations before he published them himself. Adams, like his mentor Saunders, had not been articled or served 6 years at the Royal College of Surgeons and therefore was unable to apply for a teaching hospital appointment. In 1805 he left London and went to the West Country where he established The West of England Eye Infirmary in Exeter.

The restless and ambitious Adams soon left that establishment too and sought work in Dublin, then Edinburgh, and finally the Greenwich Hospital.

Saunders died in 1810 and Adams felt that, with his knowledge of Saunders' operations, he had a right to succeed him. He was unsuccessful in his attempt and the post went to Benjamin Travers. Adams then made it known that he had been successful in performing his own operation for trachoma and offered his services to the War Ministry whereupon an Ophthalmic Institute was set up for him to operate on invalids from the army and navy. This was originally at the York Hospital in Chelsea and later in 1818 was

moved to a site on the eastern side of Regent's Park in one of John Nash's buildings. Here he rendered a free service to soldiers with Egyptian ophthalmia returning from military campaigns in Egypt.<sup>1</sup> This building was subsequently used to produce steam guns which preceded the modern machine gun.

Adams had the backing of powerful politicians but his surgeon colleagues did not accept his method because of the poor results. He was forced to resign following a wave of opposition to his controversial operation. This did not stop Adams from going on to build a large private practice. He was appointed oculist extraordinary to the Prince Regent and knighted in 1814.

In the mid-1820s he lost all of his considerable fortune in a speculative mining venture only to be rescued by a large bequest from his wife's mother. There was a stipulation in her will that required Adams to change his name to Rawson, her late husband's name, by which he was known after 1825. Sir William "Rawson" died in 1827.

Reproduced/adapted from Br J Ophthalmol, The art of surgery: Sir William Adams (1783-1827), R. Keeler, A.D. Singh, H.S. Dua, 96, 1160-1161, Sep 1 2012 with permission from BMJ Publishing Group Ltd.



Fig.1 ► Image from Sir William Adams' book pupilloplasty



Fig.2 ► Instruments used by Sir William Adams on in his operations

## MASSEURS: FOR YOUR EYES ONLY



Massage, as a form of medical therapy, is almost as old as time. Words with phonetics similar to "massage" can be found in ancient French, Arabic, Greek and Latin writings. The practice of massage seems to have originated in ancient cultures of India, China, Mesopotamia and perhaps a few others. It involves manoeuvres on the surface of the body to affect the tissues on the surface and beneath, especially muscles, tendons and ligaments. The masseur uses hands or simple tools (eg, Stones) designed to create friction, rubbing, pressure, kneading. Depending on the site of the body being massaged, the masseur may use elbows, knees and even his/her feet. Massage is designed to improve function, relax 'tired' muscles making them supple and helps with healing of injured or diseased tissues. It promotes a general feeling of relaxation and well-being. As a form of therapy it is formally recognised in many health systems with an annual turnover running into billions in any currency<sup>1</sup>.

It is not surprising therefore that someone would have considered the idea of massaging the eyes

to promote ocular well-being. Ocular massage has been known to produce a favourable effect on diseases of the eye from early times and is to be found in Grecian records. Paul of Aegina also recognised it.

The image above shows the Neu-Vita Oculizer, an instrument designed specifically for ocular massage in the early 20<sup>th</sup> century. This instrument was intended for home use and was accompanied by several pages of instructions. Its use required the black eyecups to be placed on the closed eyelids having made sure first that any dust in the apparatus was blown out by squeezing the rubber bulbs. The instrument then had to be set for the correct inter-pupillary distance.

Gentle suction on the eye was applied and the massage begun by inflating and deflating the bulb. The instructions include the statement that 'perfect sight depends on healing the whole body' which should be in perfect condition with exercise and good eating hinting perhaps at the slight scepticism associated with this form of therapy alone.



However, Pagenstecher reported "magnificent results" in 1871. Frans Donders recited his accomplishments with ocular massage before the International Congress of Ophthalmology held in London in 1872. The *Encyclopedie Francaise d'Ophthalmologie*, edited by F Lagrange and E Valude, devotes eight pages to massage citing Hoffmann of Ulm as being the first to design an instrument for mechanically massaging the eye in 1884. The Victor Company made several instruments; one in clear glass through which the operator could observe the action that was taking place (fig.1). The cups were moulded as closely as possible to the shape of the eyeball with the tubes connected to a machine capable of compression, suction or vibration of the air.

Mechanical massage of the cornea was a function offered by another Victor machine (fig.2). Elastic material was stretched across the circular mouth of the appliance and held in place by a knurled collar. The handle was connected to an ear pump which vibrated the diaphragm pneumatically

which in turn transmitted the vibrations to the corneal surface.

Ocular massage remains part of modern day interventions for specific conditions. Gentle massage to the eyelids combined with hot fomentation, to release pent up meibomian secretions in posterior blepharitis often gives relief. In the acute state of central retinal artery occlusion with an embolus it is believed to dislodge the embolus to a point further down the arterial circulation thus improving retinal perfusion. Massage through the upper or lower eye lid is also employed following trabeculectomy surgery<sup>2</sup> or glaucoma valve implantation<sup>3</sup> to aid drainage. Complications such as suture break, iris incarceration, hyphema, bleb rupture and others have been reported. In the above instances, massage is usually performed with fingers but mechanical devices are also in vogue<sup>2</sup>.

Reproduced/adapted from Br J Ophthalmol, Masseur: for your eyes only, R. Keeler, A.D. Singh, H.S. Dua, 96, 1283, Oct 1 2012 with permission from BMJ Publishing Group Ltd.

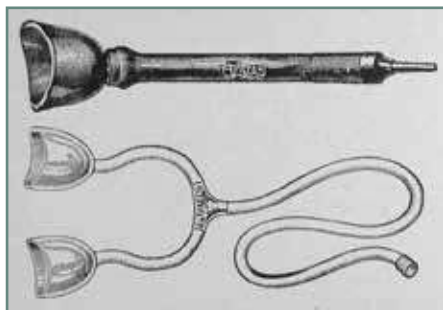

Fig.1 ► *The Victor Company glass eye cup pneumo-massager. The glass cups allowed direct observation of the eyes being massaged*

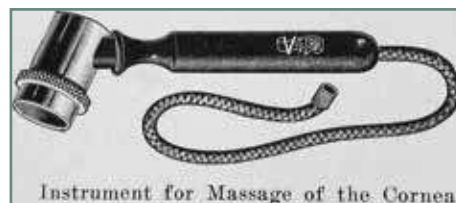

Fig.2 ► *The Victor Company, Corneal ocular massager*

1. Massage, from Wikipedia. <http://en.wikipedia.org/wiki/Massage> (accessed 18 Aug 2012).

2. Gouws P, Buys YM, Rachmiel R, et al. Finger massage versus a novel massage device after trabeculectomy. *Can J Ophthalmol* 2008;43:222-4.

3. McIlraith I, Buys Y, Campbell RJ, et al. Ocular massage for intraocular pressure control after Ahmed valve insertion. *Can J Ophthalmol* 2008;43:48-52.

# EYES THROUGH BADER'S EYES: CHARLES BADER (1825-1899)

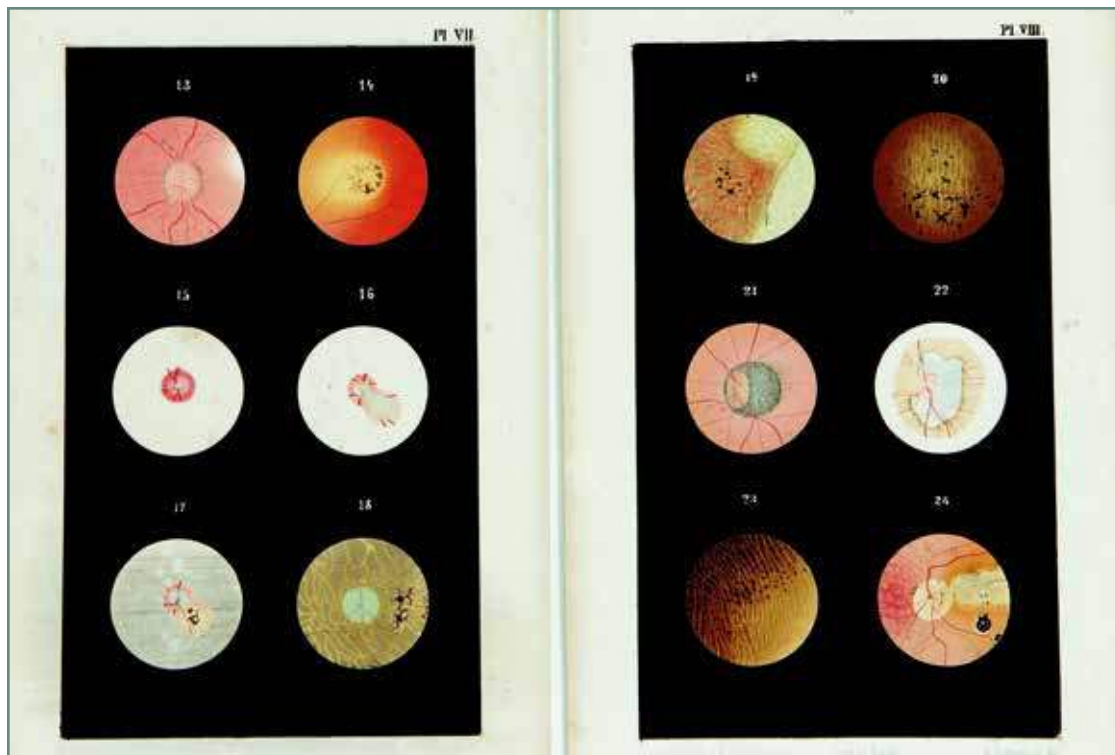

The invention of the ophthalmoscope by Hermann von Helmholtz in 1850-51 allowed ophthalmologists to see inside the living organ of sight and reveal its secrets. Without doubt this was one of the most significant, if not the most significant event in the history of ophthalmology.

A year later (1851) William Bowman (of Bowman's membrane fame) acquired one of the first models of Helmholtz's ophthalmoscope which he enthusiastically deployed at Moorfields Eye Hospital in England. Bowman's student, Charles Bader, was amongst the earliest users of the ophthalmoscope in England. In 1855 he had published an article in German on the ophthalmoscope stating that in a period of 4 weeks he had seen 600 patients at the Royal London Ophthalmic Hospital (Moorfields). He later published a book of plates in 1868 entitled "The Natural and Morbid changes of the Human Eye" (fig.1). It contained paintings of the human fundus, drawn in meticulous detail by R Schweizer, the first ophthalmic artist at Moorfields. Two of the plates are illustrated above. Bader delayed publication of the book

of plates by 1 year as he was not satisfied with the quality of print of the initial production.

Charles (Karl) Bader was born in 1825 in Freiberg, Germany.

He had his early education in Freiberg and later in Heidelberg. He participated in the 1848 German Revolution and was captured and sentenced to death. He escaped and fled to London where he settled. He joined William Bowman at Moorfields and because of his skill with the microscope he became the first curator at the hospital in 1857, with an annual salary of 25 guineas. He studied anatomy and clinical ophthalmology under Bowman who had high praise for his pupil.

A room was set aside at the hospital to create a museum and library for pathological research. It was here that Bader meticulously recorded the pathology of all the eyes enucleated by the surgeons at Moorfields (fig.2) as well as from elsewhere thus providing most of the valuable work done in Great Britain. Bader was an expert in mounting the specimen using two methods of preservation, spirit and glycerine. This was not

very successful, the spirit shrinking the specimen and making the transparent parts opaque and the glycerine caused swelling. Later in 1871, Edward Nettleship, who was also a curator, introduced glycerine jelly, a method further developed by Priestley Smith in 1883. Professor Leber in 1894 introduced the much improved formaline, a hardening and preserving agent, for long-lasting preservation of tissue whilst retaining its features.

Bader was also a keen surgeon and demonstrated to William Bowman his operation for keratoconus wherein he excised the tip of the cone using a knife and scissor and also his use of cautery to flatten the cone. Bader never became

a consultant ophthalmologist at Moorfields. He was appointed ophthalmic assistant surgeon at Guy's Hospital in 1869 and remained there until 1882 from where he performed thousands of operations with his personal set of instruments (fig.3). He also published 16 papers in the first four volumes of the Royal London Ophthalmic Hospital Reports.

Bader was an active sportsman all his life and even in his seventies, shortly before his death, he was still an excellent swimmer, horseback rider, boxer and fencer.

Reproduced/adapted from Br J Ophthalmol, Eyes through Bader's Eyes (Charles Bader 1825-1899), R. Keeler, A.D. Singh, H.S. Dua, 96, 1363-1364, Nov 1 2012 with permission from BMJ Publishing Group Ltd.



Fig.1 ▶ Plate II illustrating drawings of sections of the eye at up to a magnification of 500 times and Plate III illustrating drawings of sections from syphilitic eyes and teeth from the book "The Natural and Morbid changes of the Human Eye" by Charles K Bader



Fig.2 ▶ Bader's handwritten records of pathological specimen

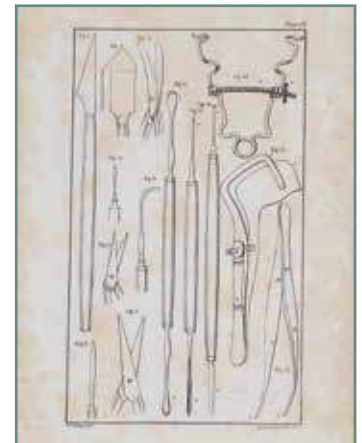

Fig.3 ▶ Plate IV from the same book as in figure 1 illustrating drawings of instruments used by Charles Bader

## CATARACT SURGERY SPRINGING INTO ACTION: THE FRENCH CONNECTION



One of the primal forces of nature is for all living beings to live as long as possible and then leave a mark behind. The usual vehicle for the latter is through genes but humans have other ways as well, of ensuring that their name lives on after they no longer exist. In medicine there is a plethora of instruments, devices, diseases and structures that carry the name of the inventor or the discoverer. Some of these have not been so popular and the name has faded with the obsolescence of the instrument or device, while others have indeed lived on "forever".

Surgery for cataracts began with the smallest of small incisions. The incision was only the width of a needle device that was inserted to displace the cataractous lens from the visual pathway, in the operation of couching. This was a popular technique for centuries but was associated with several problems, driving the development of other approaches to deal with the opaque lens. Though the origin of couching is largely attributed to the 6<sup>th</sup> century physician, Sushruta of ancient India<sup>1,2</sup> others have contested this, claiming that the operation described by

Sushruta was in fact an extra-capsular extraction of the cataract<sup>3-7</sup>. They have documented that the credit of the first extraction of the cataractous lens is erroneously attributed to the French ophthalmologist, Jacques Daviel<sup>8</sup> who performed an extracapsular extraction of the cataract on the 8<sup>th</sup> of April 1747. Daviel presented a paper before the French Royal Academy of Surgeons entitled, "A new Method of Curing Cataract by Removing the Lens" on 13 April 1752 and published it in 1753<sup>1</sup>. Daviel's procedure consisted of an incision along the inferior sclero-corneal junction for more than 180°<sup>1</sup>.

Following Daviel's publication in 1753, numerous surgeons attempted to develop a better or the best technique to make an incision for cataract extraction. Over the last 250 years every conceivable shape and size of cataract knife has been designed often without a discernible difference between some of them.

The instrument illustrated above is a rare spring-loaded cataract knife invented by Pierre Guerin of Lyon in 1786. Pierre Guerin 1742-1827 was a

French surgeon and ophthalmologist born in Lyon. He became a Fellow of the Royal College of Surgeons at Lyon where he was a demonstrator and surgeon of much experience at the Grand Hotel Dieu, Lyon. In 1800 he moved to Bordeaux where he lived and practiced until his death.

Use of the knife involved placing the ring at the end of the instrument firmly on the eye allowing the cornea to protrude through it. This also allowed fixation of the eye, keeping it steady while the incision was made. The keratome-shaped knife, when released, moved across the cornea in a fraction of a second cutting across a large arc at the periphery of the cornea. In Lyon at the beginning of the 19<sup>th</sup> century extraction was preferred over couching of the cataract.

The manufacturer of the knife was Lesueur (Le Sueur), who made a range of surgical instruments for the military. The company was established in the middle of the 18<sup>th</sup> century in Paris by a father and son team and had ceased to exist by 1835.

Another sample of this spring-loaded knife lies in the museum of the Royal College of Surgeons of Edinburgh, labelled as the 'keratome de Guerin'. It was originally presented to the Academy of Surgery, Paris in 1786 in the year of its manufacture. Guerin had made a previous attempt to design a knife for cataract (fig.1). In 1769 he developed a spring lancet-punch resembling instruments used for blood-letting. An illustration and description of this instrument can be found in his first and only book which was published under the title *Traite (Essai) sur Les Maladies des Yeux* (fig.2). It was characterised by Julius Hirschberg, the historian, as eine taube nuss ('an empty nut'). The author describes different methods of cataract extraction which both fixates the eye and performs the corneal incision but the book is only an excuse to promote a new instrument of the author's own design, he wrote.

Reproduced/adapted from Br J Ophthalmol, Cataract surgery springing into action: the French connection, R. Keeler, A.D. Singh, H.S. Dua, 96, 1449-1451, Dec 1 2012 with permission from BMJ Publishing Group Ltd.

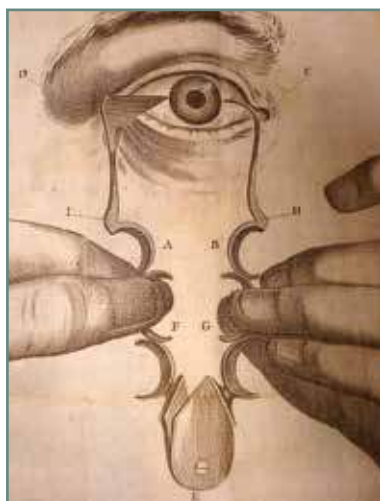

Fig.1 ▶ Diagrammatic illustration of Guerin's first attempt, in 1769, at developing a knife for making an incision in the operation to extract the cataractous lens



Fig.2 ▶ Image of the title page of Guerin's book, "Traite sur les Maladies des Yeux"

1. <http://www.ascrs.org/jacques-daviel-deceased> (accessed 20 Oct 2012).
2. Duke Elder S. System of Ophthalmology. vol. I I, p. 249. 1969 quoted by Roy PN, Mehra KS, Deshpande PS. Reference No. 3.
3. Roy PN, Mehra KS, Deshpande PS. Cataract surgery performed before 800 B.C. Brit J Ophthal 1975;59:171.
4. Kansupada KB, Sassani JW. Sushruta: the father of Indian surgery and ophthalmology. Doc Ophthalmol 1997;93:159-67.
5. Mehta H. Extra-capsular cataract removal—not couching—pioneered by Sushruta. Surv Ophthalmol 2011;56:276-7.
6. Mehta H. Extra-capsular cataract removal pioneered by Sushruta. J Cataract Refract Surg 2011;37:1365.
7. Mehta H. Author's response. Surv Ophthalmol 2012;57:584-5. doi: 10.1016/j.survophthal.2012.08.009
8. [http://en.wikipedia.org/wiki/Jacques\\_Daviel](http://en.wikipedia.org/wiki/Jacques_Daviel) (accessed 20 Oct 2012).

# FATHER OF BRITISH OPHTHALMOLOGY: RICHARD BANISTER (1570-1625)

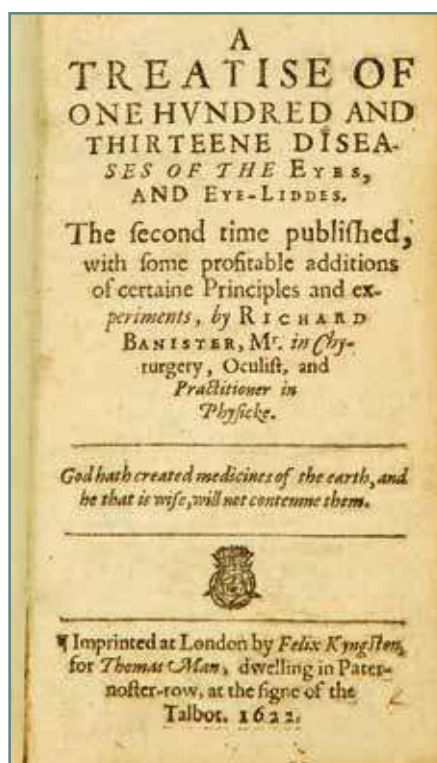

This illustration shows the title page of Richard Banister's "A Treatise of one hundred and thirteene Diseases of the Eyes and Eye-Liddes" published in London in 1622.

The title is misleading as it suggests that the author was Richard Banister. The book in fact was a translation into English of a work by Jacques Guillemeau who was a surgeon at the courts of Charles IX, Henry III and Henry IV of France.<sup>1</sup> It was first published in French in Paris in 1585 and later at Lyon in 1610 entitled "*Traité des Maladies de l'Œil* (Handbook for treatment of ailments of the eye)".<sup>1</sup> It is suggested that the first English translation was made by "A.H." which ran out of print and Richard Banister published a second edition in 1622.<sup>1</sup> This second edition is a composite volume of 240 leaves and in addition to the aforementioned translation contains material called "*Cervisia Medicata, Purging Ale, with divers aphorisms and principles*". The work was also called "Banister's Breviary of the Eyes". In the book Banister states quite plainly that the Guillemeau work is published for the second time along with two other short treatises one of

them being Walter Bayley's "A Briefe Treatise concerning the preservation of the Eye-sight". The confusion about the title would appear to be the fault of the publisher as Banister was no plagiarist.

Study of Banister's Breviary reveals the work of an honest itinerant ophthalmologist at a time when quackery was prevalent. Banister was one of the first English surgeons to specialise, almost exclusively, on ophthalmology. His claim to a surgical qualification as *Mr in Chyrurgery* in the title is borne out by documents discovered by Professor Arnold Sorsby and Robert Rutland James in their exhaustive study of the man they refer to as the Father of British Ophthalmology.

The "Breviary" is an important work. Banister was a careful observer and gives a unique account of the practice of ophthalmology in England in the early part of the 17<sup>th</sup> century. However, in the unnumbered 112 pages of the Breviary one paragraph (fig.1) stands out in which he discusses "the fit time for couchi(ng) of cataracts" followed by a paragraph on the seriousness and hopelessness of gutta serena

(blindness associated with a transparent pupil). For this latter condition he lists four reasons where no cure is possible. In the third of these he states "if one feele the Eye by rubbing upon the Eye-lids, that the Eye be grown more solid and hard, then naturally it should be...then there is no hope of a Cure". Sorsby states "Here is the first recognition of hardness of the eye as a cardinal clinical sign and a clear recognition of absolute glaucoma. Banister came very near to establishing chronic glaucoma as a distinct entity..." Two hundred years were to pass until William Mackenzie in 1830, in the first edition of his classic textbook "A Practical Treatise on the Diseases of the Eye", stated that hardness of the eyeball was a cardinal sign of glaucoma and it then became part of the teaching in ophthalmic practice.

The Breviary also denounces unqualified practitioners particularly women and foreigners. "some of these Mounte-banks take their Patients into open markets, and there for vaineglories sake, make them see, hurting the Patient, only to make the people wonder at their rare skill. Some others make Scaffolds, on purpose to execute their skill upon, as the French-men, and Irish-men did in the Strand, making a trumpet to be blown, before they went about their work".

To find out more on the biographical details of Richard Banister one has to turn to the

discovery by RR James of the anonymous and undated Sloan MS 3801 in the British Museum. James claims that the author is incontrovertibly Banister and much of the manuscript is in his own writing. In the manuscript there are some autobiographical details. Banister was 'broughte upe as a gramer scoler'. He was apprenticed for 5-6 years 'in ye practice of surgerye' to 'my neare and dear kinsman' his uncle, the famous surgeon, John Banister.

Banister settled in Sleaford where he continued to study the practice of surgery and anatomy. Banister died in 1626 and was buried in the parish church in St Mary's Stamford. An original portrait of Richard Banister hangs in one of the dining rooms at the Royal College of Surgeons of England where it has been since 1841. In 1866 it was exhibited at the National Portrait Gallery when it was wrongly shown as a portrait of his famous uncle John Banister. The portrait painted in 1620 has been attributed to Cornelius Jansen, a contemporary of Van Dyck. The Royal College of Ophthalmologists has a fine copy of this portrait (fig.2) which hangs outside the Lecture Room.

Reproduced/adapted from Br J Ophthalmol, Father of British Ophthalmology: Richard Banister (1570-1625), R. Keeler, A.D. Singh, H.S. Dua, 97, 7-8, Jan 1 2013 with permission from BMJ Publishing Group Ltd.

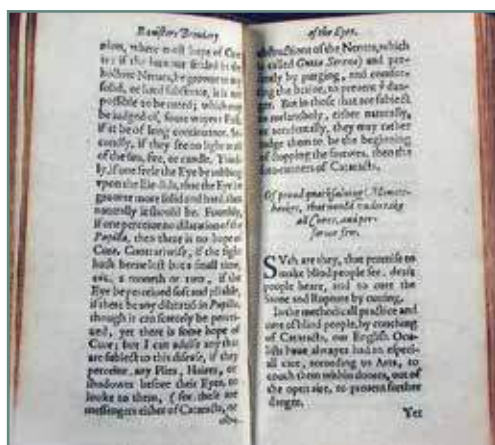

Fig.1 ▶ Two of the pages of Richard Banister's "A Treatise of one hundred and thirte Diseases of the Eyes and Eye-Liddes" published in London in 1622



Fig.2 ▶ Portrait of Richard Banister from the Royal College of Ophthalmologists, UK

## BATTLING WITH REFLECTIONS: THE BUSCH STEREOSCOPIC REFLEXLESS BINOCULAR OPHTHALMOSCOPE



The first attempt to view the fundus stereoscopically was made in 1861 when Felix Giraud-Teulon of Paris invented a binocular ophthalmoscope constructed by Nacet. At that time the source of illumination was from a gas or oil lamp. The instrument was difficult to use and was not popular. Although the instrument enabled detection of elevations of the retina such as retinal detachment, there was nothing the surgeon could do to remedy it. This also contributed to its lack of popularity. Surgical reattachment of the retina had to wait for another 65 years until the pioneering work of Jules Gonin.

An improved model followed in 1862 invented by John Z Laurence and Charles Heisch of London when they introduced a binocular ophthalmoscope with adjustable inter-pupillary distance. There then followed a long period before another attempt was made to employ a binocular eye piece to view the fundus three dimensionally. This was in 1910 by Allvar Gullstrand working with Carl Zeiss. The instrument was a large table-mounted model which used an optical system that allowed the

fundus to be viewed without annoying reflexes.

The instrument above was invented in 1929 by Professor Dr Walter Thorner (1874-1948) (fig.1) and made by the firm Emil Busch of Rathenow in Germany. The actual model shown was made in 1931. It was recovered from the ashes of the firm's factory which was destroyed in World War II. The late Tom Black-Kelly from Bath acquired it from Berlin in 1950. This instrument called the Busch Stereoscopic Ophthalmoscope (fig.2) was also reflexless that is, eliminating the interfering reflections from the cornea.

Walter Thorner had been the first to employ an optical system to avoid reflexes in his table mounted model of 1898 made by Schmidt and Haensch of Berlin. The same company also made a hand-held monocular reflexless ophthalmoscope in 1909 a year before the one made by Gullstrand-Zeiss. The firm of Emil Busch took over the design and manufacture of this instrument in 1914 but it was not until 1926 that production commenced. The binocular version of this instrument by Busch was made between 1929 and 1932.



As with the Gullstrand-Zeiss ophthalmoscope a reflex free image of the fundus was achieved by light entering the eye through one half of the dilated pupil and viewed through the other half. However the Busch-Thorner instrument used a mirror arrangement to achieve this (fig.3) as opposed to lenses in the Gullstrand-Zeiss model. An account of Professor Thorner's life and other optical inventions can be found in the article "Empowering eyes:The Thorner Optometer" on page 52.

Ophthalmologists had to wait until 1945 to experience the first modern head-worn binocular indirect ophthalmoscope invented by Charles Schepens. A teacher once said to his pupils "Direct ophthalmoscopy is like a burglar trying to find his way through a dark room with a torch (flashlight). Indirect ophthalmoscopy is like the owner entering the room and flicking the light switch on; most of the room can be seen from where he stands".

Reproduced/adapted from Br J Ophthalmol, Battling with reflections: the Busch stereoscopic reflexless binocular ophthalmoscope, R. Keeler, A.D. Singh, H.S. Dua, 97, 119-120, Feb 1 2013 with permission from BMJ Publishing Group Ltd.



Fig.1 ▶ Walter Thorner (1874-1948)



Fig.2 ▶ The Busch-Thorner Binocular Ophthalmoscope

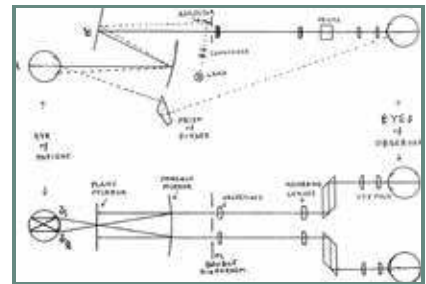
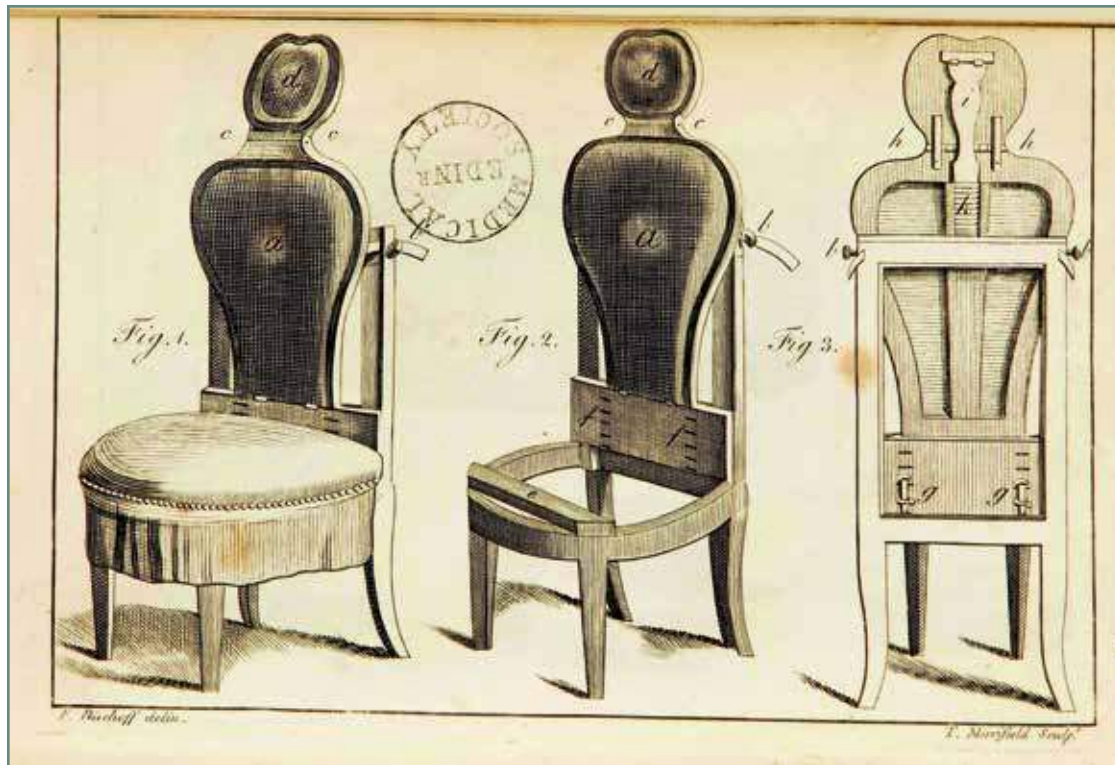

Fig.3 ▶ Line drawings of the Busch-Thorner ophthalmoscope

## STANDING UP TO THE OPERATION



The position of the patient and surgeon relative to each other during eye surgery has seen its own evolution. First both the patient and surgeon sat; then the patient sat while the surgeon stood; then the patient lay down and the surgeon stood. Several contemporary eye surgical procedures involve the use of gadgets and equipment requiring the surgeon to use both hands and both feet. This mandates that the surgeon is seated while the patient lies down. The illustration above comes from "A Treatise on the extraction of the Cataract" by Frederick Bischoff published in London in 1793. It shows an operating chair designed by the author with various adjustments that could be made to it. The patient at this time in the history of ophthalmic operations was most frequently operated on in a sitting position the head being held firmly against the chest of the assistant. Bischoff preferred to operate with the patient sitting upright on a chair stating that 'It is impossible then (sic) a man should be as immoveable as a machine'.

The backrest of his chair could be tilted forwards or backwards and the headrest which consisted

of a concave cushion could also be tilted back for greater security of the head and prevent slipping. The overall height of the chair was constructed for Bischoff himself with adjustments for various sizes of patients including children catered for with blocks of wood placed under the seat cushion. The cushion itself was slotted into the backrest and held with iron pegs. A trial run with the patient seated in the chair was carried out a few days before the operation so that the exact settings could be replicated on the day of the operation. Fig.1 shows an eye bandage, used post-operatively, made of two thicknesses of black silk to prevent any light reaching the operated eye.

Bischoff preferred to withdraw the upper eyelid with an elevator made of malleable silver held up by the assistant (fig.2). Bischoff was a follower of Professor Richter's (Gottingen) method of cataract extraction and used his knife shown on the right (fig.2) for the initial section. In his book he quotes Richter verbatim for no less than seven pages on the method of making the incision with the knife. Special emphasis was placed on the necessity of using the best

quality of knife with the sharpest point which should not be too rigid. He quotes the case of a famous oculist who lost the tip of the knife in the eye and was unable to recover it, not having a magnet to hand and subsequently losing the eye to infection. (Could this be the first mention in ophthalmic literature of the use of a magnet to retrieve a foreign body in the eye?).

The instrument with the beautifully carved handle (fig.2) "is a Parma spear, corrected by Casaamata, to make an unsteady eye firm". The pointed needle with stop pierces the cornea and is used as a fixator (fig.3).

The book continues with advice and guidelines such as the operation "should be performed on one eye only at a time, in case the patient should go blind in both. The contrary practice can only have originated in the precipitance of some itinerant oculist who not having patience to wait for recovery of the first eye undertake the double operation, for the sake of the double fee".

There is no known birth and death dates for Frederick Henry Bischoff which is strange as he must have been well regarded to justify the

announcement in the London Gazette on the 3<sup>rd</sup> of January 1792 that the Queen (Caroline, wife of George III) "has been pleased to appoint Frederick Bischoff to be oculist to her Majesty". On the title page Bischoff claims also to be oculist to his Majesty (George III) in the Electorate of Hanover but no such announcement can be found in the London Gazette to confirm this.

An announcement however in this same Gazette in 1794 may however explain his reduced circumstances as it states that he was a prisoner in the King's Bench Prison for debt. No such misfortune befell his father Ferdinand Bischoff, an Hanoverian, who was a famous artist and engraver exhibiting and working at the Royal Academy from 1823-1849.

Benjamin Bell, the great surgeon and anatomist, reproduced the plates illustrated in this article in his monumental "A System of Surgery in 1801". Bischoff is also referenced in several other journals.

Reproduced/adapted from Br J Ophthalmol, Standing up to the operation, R. Keeler, A.D. Singh, H.S. Dua, 97, 251-252, Mar 1 2013 with permission from BMJ Publishing Group Ltd.



Fig.1 ▶ The drawings illustrate the eye bandage used by Bischoff and some components of his "operating chair"

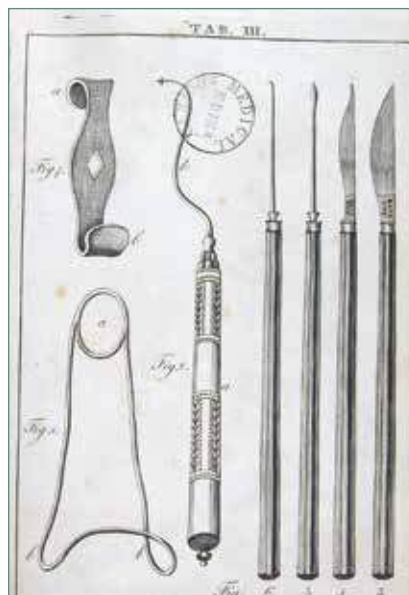

Fig.2 ▶ Set of instruments used by Bischoff for cataract surgery

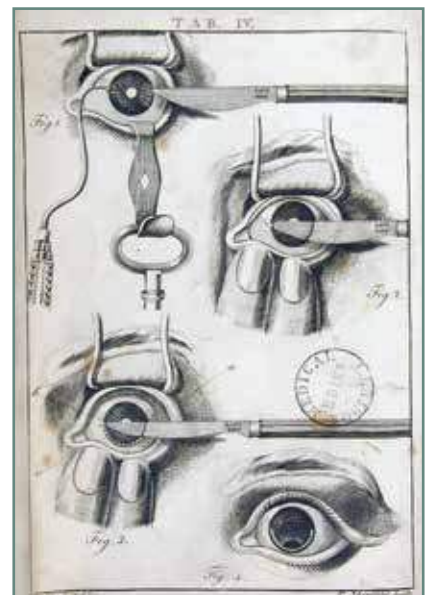

Fig.3 ▶ Illustration of the instruments in use during cataract surgery

## A MASTER MASTERING THE OPHTHALMOSCOPE: EDUARD VON JAEGER



No matter from which perspective one views the history of Ophthalmology, the invention of the ophthalmoscope by Helmholtz stands out as one of the most, if not the most significant event. Several modifications and adaptations followed some surviving and others remaining buried in History.

The ophthalmoscope above is that of Eduard von Jaeger 1818-1884, (fig.1) who was the grandson of George Beer and son of an even more famous ophthalmologist, Friedrich Jaeger. Friedrich Jaeger was mentor and teacher of his son Eduard and of Frédéric Jules Sichel (credited with bringing modern ophthalmology to France) and young Albrecht von Graefe, all of whom he taught surgery of the eye and each of them went on to become outstanding ophthalmologists.

Eduard Jaeger invented an ophthalmoscope which combined the merits of the recently introduced direct ophthalmoscope by Hermann von Helmholtz and the newly developed Theodor Ruete ophthalmoscope using the indirect method

of ophthalmoscopy. He achieved this by using an interchangeable circular holder with the "plates" of Helmholtz in one and a concave mirror with central aperture by Ruete in the other. Jaeger preferred the direct method of ophthalmoscopy which offered an erect image and high magnification.

Jaeger's speciality was sketching and painting the fundus. He spent many years meticulously reproducing the fundi of his patients some of whom had to endure more than 20 visits of up to 3 hours duration. The result of his endeavours was the publication of the first of a two volume collection of chromolithograph plates illustrating the healthy and diseased fundus in 1855. This was followed in 1869 by one of the most important ophthalmoscopic atlases of the nineteenth century. Jaeger also published a book in 1861 on the structure of the emmetropic, myopic and hyperopic eye and the principle of accommodation. He was the first to use an ophthalmoscope as a means of refracting the eye. He was also the inventor of the well known Jaeger Test Type for reading.

His ophthalmoscope set depicted above shows the instrument set up for use with the Ruete concave mirror. The box contains eight concave lenses and four convex ones for the correction/measurement of the patient's refractive error. The lens on the thin handle is a high power condensing lens. The "mirror" seen in the circular holder is comprised of three thin glass plates held together, similar to the Helmholtz (fig.2). When placed in the ophthalmoscope head at an angle of 60° there is a partial polarising effect allowing some of the light to be projected on to the fundus while the observer views the illuminated fundus through the semi-transparent plates. This method of projecting light into the eye and viewing the illuminated fundus on the same axis was Helmholtz's invention in 1851 which revolutionised ophthalmology.

In 1853 Jaeger was passed over to become Professor at the University Eye Clinic in Vienna. The coveted position went to Ferdinand Arlt instead. However, many years later in 1883, he was finally named Professor at the new University Eye Clinic II but was unable to make any impact, as he passed away 9 months later.

This Jaeger ophthalmoscope was gifted to the Royal College of Ophthalmologists from the collection of antique instruments originally held at the Glasgow Eye Infirmary. The instrument is said to have been used by Sir William Mackenzie who founded the hospital in 1824. If this is true he could not have used it with much confidence as he was far from enthusiastic about the use of the ophthalmoscope stating that it was dangerous to shine such a strong light directly on the retina as it might damage the retina.

Reproduced/adapted from Br J Ophthalmol, A master mastering the ophthalmoscope: Eduard von Jaeger, R. Keeler, A.D. Singh, H.S. Dua, 97, 387-388, Apr 1 2013 with permission from BMJ Publishing Group Ltd.



Fig.1 ▶ Eduard von Jaeger (1818-1884)

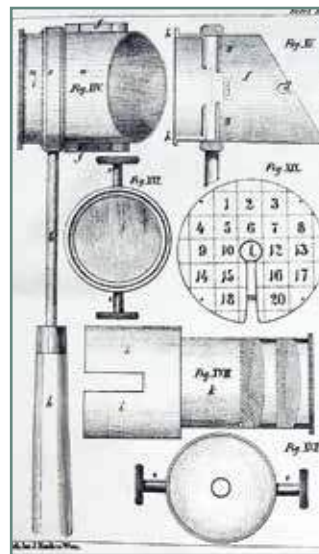

Fig.2 ▶ Component parts of the Jaeger ophthalmoscope

## EYEING THE BEST



This image is from a book entitled "A Manual of the Diseases of The Human Eye", intended for surgeons commencing practice from "The Best National and Foreign Work on the Human Eye".

To give it proper perspective and context, it must be appreciated that the book was written in 1821. Credit for the book probably goes to several individuals. It was first published in German by Karl Heinrich Weller in 1819, but by his own admission he had taken much of the content from the published work of Professor Georg Beer.

An English edition of this work was published a couple of years later, translated and edited by George Monteath. Like Weller, Monteath added some of his own observations to the content of the book. Although the source of the material is not clear, it was obvious that this book had supplanted the English translation of Antonio Scarpa's Textbook of 1806 and 1818, which until then had been the main source of information and a reference text for ophthalmologists.

The paintings of eye conditions above are from Plate II. There is a full explanation for each figure on this plate. Fig.2 and 3 show a case of conical cornea.

*"Both figures exhibit the conical projection of the cornea. It is observed in both, that the highest point of the projected cornea includes its centre, as is almost always the case. In the second Figure copied from Wardrop, sketched only in outline, the disease is much evolved; but in fig.3 there is a particularly large conical projection, which seldom occurs. Moreover the cornea may be distinctly recognised as perfectly transparent in this case. (Demours)"*

Although much of the content (fig.1) is derived from Professor Beer, other contributions from well-known ophthalmologists of the time are quoted throughout the book.

Georg Joseph Beer (1763-1821) started the first eye hospital in Vienna in 1786 and became the most celebrated ophthalmic surgeon of the period. He founded the "Vienna School of Ophthalmologists" with disciples such as Friederick von Ammon and Eduard Jaeger, his grandson. He published extensively.

Karl Heinrich Weller (1794-1854) was born in Halle and settled in Dresden having graduated as a doctor of medicine there in 1817. He worked in Dresden as a physician and ophthalmologist

until his death. He was a successful author. He wrote this book in 1819. With each new published edition, culminating in the 1830 Berlin edition, Weller included more and more of his own observations. Over the period, the book was translated into English, Russian, French and Italian. The English translation anglicised his name to Dr Charles H Weller.

George Cunningham Monteath (1788-1828) was a Scotsman and co-founder of the Glasgow Eye Infirmary with William Mackenzie. He graduated MA in 1805 and trained at the London Infirmary in Charterhouse Square before returning to

Glasgow. He subsequently became the leading oculist in Glasgow, being the first to dedicate himself to ophthalmology alone. It was to Monteath that Mackenzie turned with the idea of setting up an eye infirmary. Initially, there were no beds in the infirmary and both surgeons had to operate in the patient's home. Tragically the promising start that these two surgeons had made ended when Monteath died suddenly at the age of 40.

Reproduced/adapted from Br J Ophthalmol, Eyeing the best, R. Keeler, A.D. Singh, H.S. Dua, 97, 543-544, May 1 2013 with permission from BMJ Publishing Group Ltd.



Fig.1 ► Colour plates from Weller's book showing a variety of anterior segment images depicting diseases of the lids, conjunctiva, cornea, tumours and gross pathology

# LEECHING BLOOD



Bloodletting had its day, based largely on the concept of "evil humours" that accumulated in the body and caused disease, when it was widely practised in the early years of organised medicine. Ancient medicine is rife with examples of bloodletting as a means of "curing" a number of conditions including those associated with excessive loss of blood such as nose-bleeds and menorrhagia!! As bloodletting was a "surgical" procedure it was devolved to the barbers who performed this and other interventions. The barber's pole, painted with red and white spiralling stripes, is a relic from the past when it was a symbol of the medical procedures performed by barbers, the red and white stripes representing the bloodied and clean bandages.

The early history of ophthalmology documents bloodletting, occupying several pages in Galen's manuscripts. Hippocrates, the "father of medicine" in his Hippocratic aphorisms declares bloodletting as one of the main treatments for eye diseases. He says in one short sentence "Ocular diseases are cured by drinking wine or by a bath or by purging or by bloodletting

or by a cleansing medication". This statement prevailed for 2000 years.

Even in the first part of the 19<sup>th</sup> century bloodletting was praised as the first and most important treatment for severe ocular inflammation including for severe reaction after a cataract extraction. Another reason for bloodletting was the association of disease and reddening of tissue.

Two advocates of bloodletting, Rowley and Ware, practised localised bloodletting by applying leeches to the temple despite the side effect of causing swelling of the eyelids. James Wardrop, a "far-seeing physician" in about 1827 took from a woman with ocular gonorrhoea no less than 170 ounces of blood within a few days so that "she looked like a wax figure" (*Hirschberg Vol 5 p.275*). It was not surprising that many became blind as a consequence of this treatment.

Bloodletting by the application of leeches to suck out blood was widely practised as an ancient interventional procedure. By the beginning of the 18<sup>th</sup> century leeches became expensive due the increased usage for medicinal purposes. The



cultivation of leeches by leech farmers became a thriving industry. It is thought that France alone imported over 42 million leeches in 1 year. Methods were even employed to re-use leeches. So extensive was their use that in the 1830s that demand outstripped supply. Thereafter there was a steady decline in the practice though live leeches were still occasionally used at Moorfields Eye Hospital in the 1960s.

It is not surprising that attempts to develop "artificial leeches" were made driven by the cost and availability of the natural counterpart. Moreover, the anticoagulant effect of a live leech bite was often difficult to stop so that an artificial leech offered a distinct advantage.

The instrument shown is an artificial leech. This method of withdrawing blood comes under the category of scarification as opposed to venesection for bloodletting. Medical catalogues are full of instruments known as scarifiers and scarificators. The free flow of blood was followed by wet cupping. In this form a scarification was made over a weal created by an exhausted cup and another exhaustion cup was applied to collect the blood. These cups could hold about four ounces and in expert hands a pint of blood could be extracted in five cups. Such a large amount was not the norm in ophthalmology.

Artificial leeches such as the one illustrated here attempted to imitate the bite of a leech but was really a scarificator not unlike a corneal trephine. The "trephine" part of Baron von Heurteloup's artificial leech was placed in the brass barrel. The circular blade was adjusted for depth by means of the screw at the top of the unit (fig.1).

By rotating the upper part of the brass holder a spring was wound. On its release a laceration of the temple, where it was usually placed, resulted. This could be repeated two or three times. As the blood started to emerge through the lacerations, the glass barrel was placed over them and suction applied by unscrewing the toggle.

This artificial leech was invented in 1864 by Charles Louis (Baron von) Heurteloup (1793-1864) who was a French urologist. Together with Jean Civiale (1792-1867) he also introduced the practice of lithotripsy, the grasping/crushing and extraction of urinary tract stones.

The practice of bloodletting or phlebotomy as it is now called is not extinct. Controlled withdrawal of blood is undertaken to treat conditions such as polycythaemia and haemochromatosis. Bizarre though it may sound, the use of leeches too has re-emerged in modern medicine. In plastic and reconstructive surgery, such as joining of severed fingers and fashioning of skin flaps, arterial anastomosis allows oxygenated blood into the affected site but lack of venous anastomosis results in swelling (edema) and congestion of the tissue. This venous insufficiency can lead to compromised circulation and death of tissue. Leeches applied to the site help to decongest the tissue and reduce swelling. A single leech can suck between 5 to 15 ml of blood (4 to 6 times its body weight) in about 10-20 min. The bite is generally painless or not more than a mosquito bite or two.

Reproduced/adapted from Br J Ophthalmol, Leeching blood, R.Keeler, A.D. Singh, A. Dua, H.S. Dua, 97, 679, Jun 1 2013 with permission from BMJ Publishing Group Ltd.



Fig.1 ► Components of the von Heurteloup's artificial leech. The circular trephine at the end opposite to the brass screw was used to make an incision in the skin at the site of bloodletting

# AUTHORS, BOOKS AND EYES...NOT A FACE FULL OF EYES

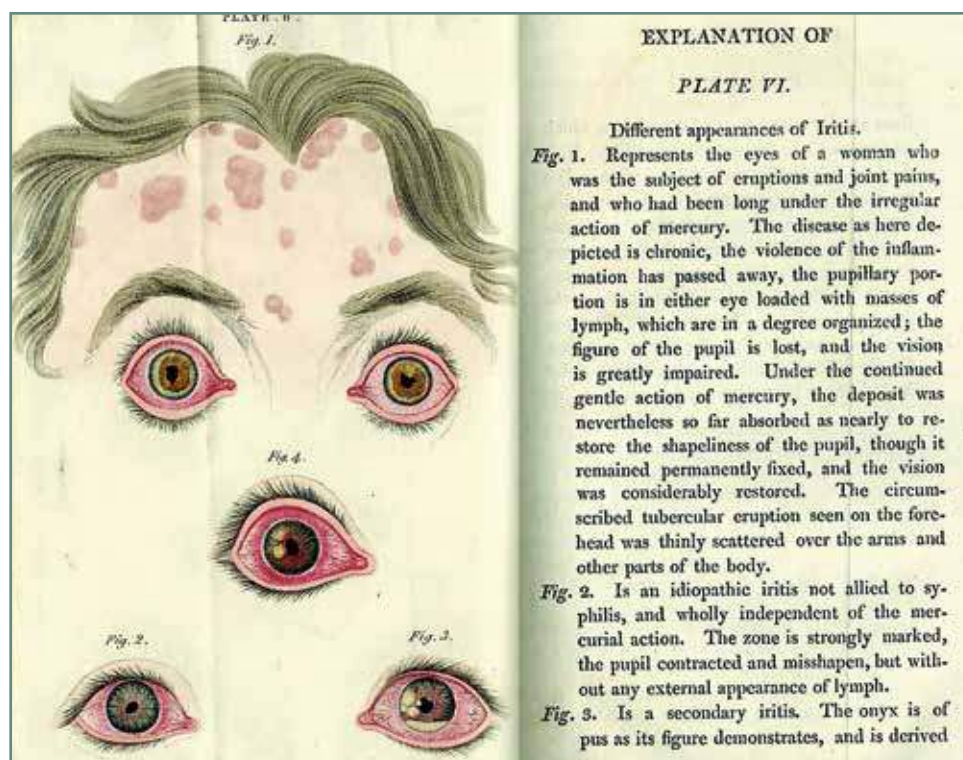

Astley Cooper and Benjamin Travers were two of the most influential surgeons of the early 19<sup>th</sup> century. They jointly wrote a book entitled "Surgical Essays", which was published in 1818. The essays were on a variety of subjects such as dislocation, wounds, ligatures on the aorta and an essay on tumours. The two volume book contained only a single essay on an eye related subject by Benjamin Travers. Both volumes are included in the antiquarian library of The Royal College of Ophthalmologists. A third volume with another essay on an ophthalmic subject written by Travers was intended but never materialised.

The 40 page essay by Travers, consisting mainly of case histories was on the subject of iritis. A plate from the book is reproduced here. In his essay Travers puts forward the beneficial use of mercury in the treatment of iritis berating European practitioners for not introducing it "it is now by a multitude of facts incontestably established as a remedy of unfailing efficacy in the most acute form and on every variety of inflammation of the iris". Sir Astley Paton

Cooper (1768-1843, fig.1) was born in Norfolk and studied anatomy and surgery under John Hunter and Henry Cline in London. He went on to become consultant surgeon at Guys and St Thomas hospitals enjoying a glittering career with many distinctions including a knighthood and peerage. It was Cooper who had originally suggested to John Cunningham Saunders that he should open a specialist eye hospital in London. Saunders founded The London Infirmary for Curing Diseases of the Eye (Moorfields Eye Hospital) in 1805.

Saunders had been house pupil to Cooper and was a highly regarded demonstrator of anatomy at Guys.

When Saunders died five years later in 1810, Cooper immediately took over the running of the hospital until someone appropriate could be appointed. Cooper had also operated on eyes and is famously quoted as saying "I have made many mistakes myself in learning the anatomy of the eye, I dare say I have spoiled a hatful; the best surgeon, like the best general, is he who makes the fewest mistakes."

The appointment went to Benjamin Travers who was to continue in this position until 1817. The choice of Travers was not altogether surprising. His father, a wealthy city merchant, also called Benjamin was chairman of the committee to raise funds to found the hospital and was well known to Cooper. It was largely due to Benjamin Travers' reputation for integrity that ophthalmology in England was rescued from quackery.

Benjamin Travers (1783-1858, fig.2) studied under Astley Cooper and was his first pupil. He obtained his MRCS in 1806 and became prosector (one who dissects cadavers for instruction or determining pathology) at Guys Hospital. He was also assistant surgeon to the

Volunteer Brigade of the East India Company. Travers became a Fellow of the Royal Society in 1813 and two years later was appointed surgeon at St Thomas having been joined at the London Eye Infirmary by William Lawrence the year before. Travers continued his career as an ophthalmologist and vascular surgeon. In 1820 he wrote "Synopsis of Diseases of the Eye and their Treatment" which was the first extensive English text-book on the eye. Travers was appointed Surgeon Oculist to Queen Victoria in 1837 and Prince Albert in 1840.

Reproduced/adapted from Br J Ophthalmol, Authors, books and eyes...not a face full of eyes, R. Keeler, A.D. Singh, H.S. Dua, 97, 803, Jul 1 2013 with permission from BMJ Publishing Group Ltd.



Fig.1 ▶ Sir Astley Cooper (1768-1843)



Fig.2 ▶ Benjamin Travers (1783-1858)

## SCREENING FOR PRESSURE: THE BERENS TOLMAN TONOMETER



In April 1950 Conrad Berens MD (fig.1) and Charles Tolman BS, a consulting engineer, announced in the Journal of the American Medical Association an instrument called "Ocular Hypertension Indicator (Tonometer)". The instrument was designed to allow general practitioners to screen eyes for the presence of pressure elevated above the normal. This would allow them to refer for further investigation and possible treatment those individuals who demonstrated a value above normal, which was set at 25 mm of mercury and thus prevent many eyes from going blind. The instrument is depicted above. The foot plate of the instrument was constructed to correspond with the popular Schiøtz tonometer introduced 45 years previously. There was a free moving central plunger with two closely spaced lines engraved around its top. The top of a hexagonal holding piece had a plastic moulded prism with a broken line engraved on it. When the line on the free moving plunger was on the same level as that on the prism the patient's intraocular pressure would be 25 mm of mercury. The thickness between the engraved lines on the

plunger represented 3 mm of mercury allowing a measure of the pressure for example; two thicknesses above the line engraved on the prism would indicate an intraocular pressure of 31 mm of mercury.

The plastic moulded prism was designed in such a way that the alignment of the engraved lines could be seen from the side or from above (fig.2).

The instrument was made by the O Gulden Company of Philadelphia but attracted a lot of attention due to the status and reputation of its inventor Conrad Berens (1889-1963). Berens was a very talented sportsman with skills in tennis, swimming, golf and yachting. However, it was as a clinician, author, organiser and teacher of ophthalmology that he excelled. He was to become one of the most prominent ophthalmologists of his generation in the USA. He was the son of an ophthalmologist also called Conrad Berens who practiced in Philadelphia.

Berens graduated in medicine in 1911 from the University of Pennsylvania. In 1913 he became a house-surgeon in ophthalmology at the

New York Eye and Ear Infirmary and remained connected to this institute for the rest of his life. He established a research department in the Infirmary which was named after him. This became one of the most progressive departments in New York innovating general medical surveys, pre-operative bacteriological tests and the use of sterile gloves and sutures for wound closure. The first course in orthoptic training also started here. During this time he served as consultant to ten other hospitals in the New York area.

Berens was also well known for his work in the armed services. In World War I, he saw service in France in the Medical Corps. He founded the School of Aviation Medicine of the US army (previously the Research Laboratory for Aviation). In World War II he was national civilian consultant to the Air Force Surgeon and later the Surgeon General of the US Air Force.

Berens accomplishments and contributions did not end with those described above. He was a prolific writer and an organiser of societies for ophthalmology. The book entitled *The Eye and its Diseases*, which he edited, was published in 1936 was a compilation of specialist chapters from eighty of the world's renowned international ophthalmologists, including from the UK. He organised the establishment of the Association for Research in Ophthalmology. He co-founded the Pan-American Association of Ophthalmology. With Dr Daniel Kirby he set up the first graduate course in ophthalmology at the New York University Bellevue Medical School.

He became Chairman of the Council for Research in Glaucoma and chairman and president of numerous other boards and councils.

Reproduced/adapted from Br J Ophthalmol, Screening for pressure: the Berens-Tolman tonometer, R. Keeler, A.D. Singh, H.S. Dua, 97, 954, Aug 1 2013 with permission from BMJ Publishing Group Ltd.

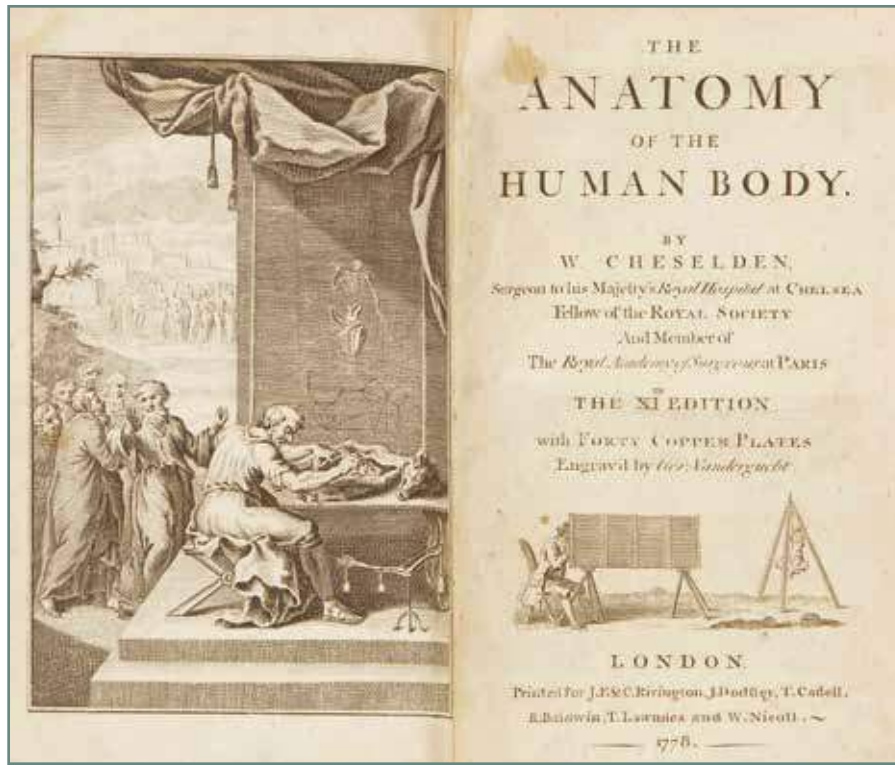

Fig.1 ► Conrad Berens (1889-1963)



Fig.2 ► Top view of the Berens-Tolman Tonometer. The moulded plastic prism and the lines for alignment to ascertain pressure above or below normal are illustrated

# BONES AND EYES: WILLIAM CHESELDEN 1688-1752



The illustration above comes from the frontispiece of the 11th edition of Anatomy of the Human Body by William Cheselden (fig.1) published in 1778. The first edition appeared 65 years earlier in 1713.

This was an important work on anatomy for many years and became a standard English textbook in the medical schools running into 13 editions.

A chapter is devoted to the anatomy of the eye not only the human eye but also eyes of animals. Cheselden mentions the examination of the eye of a crocodile which Sir Hans Sloane had kept preserved in spirits. The chapter ends with "An account of observations made by a young gentleman who was born blind, or lost his sight so early that he had no remembrance of ever having seen, and was couched between thirteen and fourteen years of age". Cheselden is credited with performing the first operation ever that resulted in "full" recovery from blindness. His account of the patient's visual experience after the operation is fascinating. At being shown his father's picture in his mother's locket he was "vastly surprised ; asking, how could it

be, that a large face could be expressed in so little room..." "...upon being told what things were, whose form he knew before from feeling, he would carefully observe, that he might know them again."

There are two plates in the book, one showing how an object can be seen by the eye and the other illustrates three operations on the eye including one on how to cut an artificial pupil. He is also credited as being the first person to perform this operation, which was published in the Philosophical Transactions of the Royal Society in 1727 with a plate showing the instruments he used (fig.2). In the engraving on the frontispiece reproduced on the cover of this issue, Cheselden can be seen drawing a human skeleton through a large camera obscura. The skeleton is held upside down so as to appear upright when viewed through the camera obscura. He is best known for his publication Osteographia or anatomy of the bones. This massive volume contains many line drawings of the human anatomy which were mainly drawn by others but under Cheselden's direction.

William Cheselden was born in Leicester in 1688. He was a pupil of William Cowper, the distinguished anatomist and surgeon. He then became apprenticed to Mr Ferne at St Thomas' Hospital. At the age of 23 he started giving lectures on anatomy, 35 of which were published in an illustrated manual. These lectures were given in his home instead of the hospital as Cheselden had attracted serious disapproval from the Barber Surgeons for not getting their permission to dissect executed criminals. In 1714 Cheselden applied twice, unsuccessfully, for a position at St Thomas. In 1718 he applied a third time and was appointed assistant surgeon, a year later becoming a full principal surgeon. In 1723 he published his treatise on the "High operation for stone" modifying it later to his own Lateral Lithotomy. In 1728 he introduced his operation for the artificial pupil. Cheselden was regarded by those at St Thomas as their greatest surgeon. His fame was not so much as an eye surgeon but for the skill and dexterity he demonstrated in his method for cutting for stone using the lateral lithotomy method which became the standard for surgeons for the next 150 years. Cheselden was an extremely fast operator removing a stone

in under 1 min much appreciated by his patients before the use of anaesthesia was used for such surgical operations.

Dr Richard Mead was senior to Cheselden by 15 years and had retired before Cheselden joined St Thomas. Both were outstanding surgeons as reflected in a couplet by Alexander Pope on Mead's retirement:

*"I'll do what Mead and Cheselden advise, To keep those limbs and to preserve those eyes"*

When Pope was taken ill, Cheselden took him into his own home in Queens Square to attend to him.

On the founding of St George's Hospital in 1733 Cheselden became one of the surgeons and in 1737 he resigned from St Thomas and all other hospitals and became resident surgeon at Chelsea Hospital. He died in 1752 after eating hot buns and drinking ale on a visit to Bath. This was not an altogether salubrious end to a man Pope called "the most noted and most deserving man in the whole profession of chirurgery."

Reproduced/adapted from Br J Ophthalmol, Bones and Eyes: William Cheselden (1688-1752), R. Keeler, A.D. Singh, H.S. Dua, 97, 1093-1094, Sep 1 2013 with permission from BMJ Publishing Group Ltd.

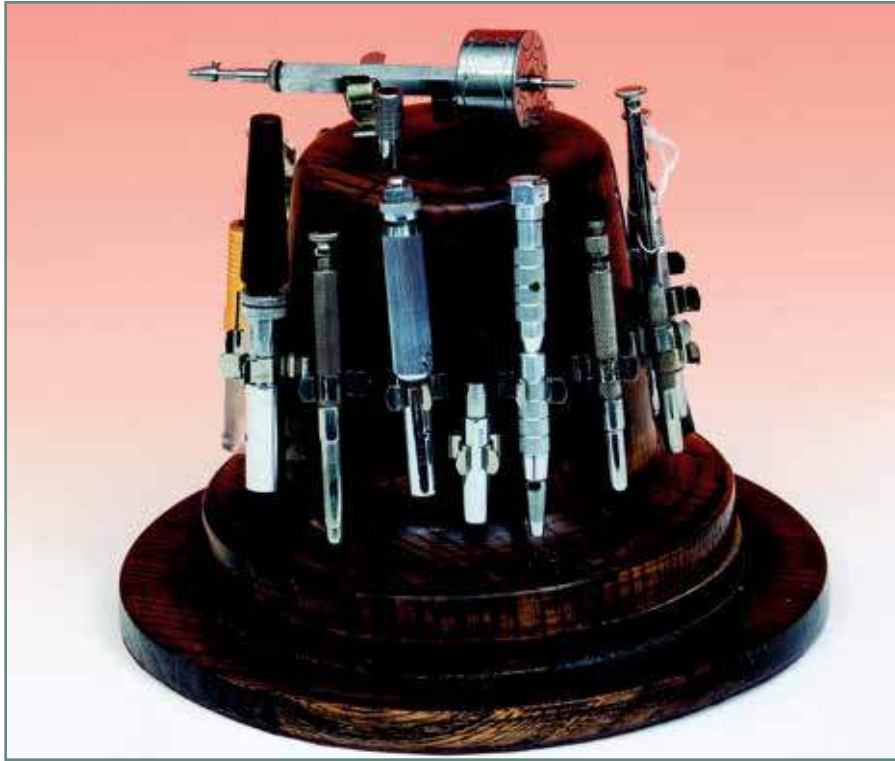

Fig.1 ► Bust of William Cheselden (1688-1752)



Fig.2 ► Cheselden's operation for formation of a new pupil by cutting the iris

## CROWN OF TREPHINES: FOR THE KING OF CORNEA



This unique crown of trephines was presented to Sir Benjamin Rycroft (fig.1) by his colleagues at the Queen Victoria Hospital, East Grinstead, on the occasion of his 60<sup>th</sup> birthday in August 1962.

Fourteen different trephines are attached around the circumference of a wooden stand. The "jewel" on top of the crown is an Arthur von Hippel clockwork trephine. Sir Benjamin Rycroft's main contribution to British ophthalmology was his pioneering work on keratoplasty and the part he played in the drafting of the Corneal Grafting Act 1952. Rycroft was not the first to perform successful keratoplasty in the UK. That accolade goes to another Knight, the Welshman, Sir Tudor Thomas (fig.2), who in 1930 demonstrated clear corneal grafts on rabbits and presented this work to the 50<sup>th</sup> annual meeting of the Ophthalmological Society of the UK. The first human corneal transplantation in the UK was carried out by him at Guy's Hospital in November 1930 but not reported until 1933.

In 1937 he presented 14 cases at The Central London Ophthalmic Hospital.

Sir Tudor Thomas realised that there would be a shortage of donor material if many transplant

operations were performed, due to the restriction imposed by the Anatomy Act of 1832. In 1947 he devised a method of taking the donor graft directly from the cadaver eye.

Benjamin Rycroft studied medicine at St Andrews University from 1919 to 1924 and shortly afterwards went into general practice in Bradford. He soon took up ophthalmology dividing his time between studying in London and carrying on his general practice in Bradford. He later moved south and became a Clinical Assistant at St George's Hospital and later at Moorfields having obtained his FRCS in 1931. He became Hunterian Professor and Leverhulme Scholar at the Royal College of Surgeons of England and a Lang Research Scholar at Moorfields Eye Hospital. He also had several staff appointments including one at the Royal Eye Hospital. At the outbreak of the war in 1939 he joined the Royal Army Medical Corps rising to the rank of Lieutenant-Colonel and culminating in his appointment as ophthalmic adviser to the army in Italy.

After the war he resumed his practice with several hospital appointments including the



Queen Victoria Hospital, East Grinstead. This was originally a cottage hospital, which on the outbreak of war had become a major centre for plastic and jaw surgery under the brilliant pioneering surgeon Archibald McIndoe (1900-1960). At the invitation of Sir Archibald, Benjamin Rycroft was invited to set up a corneo-plastic unit in 1947 which was to deal mainly with post war injuries. The two of them played a major part in the drafting of the Corneal Grafting Act of 1952 which allowed surgeons in the UK to practice keratoplasty on a reasonable scale for the first time. Following the Act, Rycroft foresaw the need for eye banks in the UK, the first of which was established at East Grinstead.

In 1955 Rycroft edited the first book in English of essays on corneal grafting and in 1960 he was knighted for his work. In 1964 he received the most blessed order of Setia Negara Brunei from

the Sultan of Brunei. That year Sir Benjamin also gave the Hunterian Lecture on "Contemporary views on the surgery and biology of the corneal graft". In his lecture he traced the origin of this operation to Erasmus Darwin, grandfather of Charles Darwin who in 1797 had the idea of employing a trephine to excise scarring. Before him, Pellier de Quengsy in 1771 mentioned the possibility that transparent material could replace the scar in the cornea. Neither Darwin nor Pellier attempted the operation.

Rycroft gave the Doyne Memorial Lecture at the Oxford Ophthalmological Congress in 1965 in which he stated that "any ophthalmic surgeon who performs a corneal graft in this country is forever in the debt of Tudor Thomas." Two years after this lecture he died suddenly at the age of 65.

Reproduced/adapted from Br J Ophthalmol, Crown of trephines:for the king of cornea, R. Keeler, A.D. Singh, H.S. Dua, 97, 1230, Oct 1 2013 with permission from BMJ Publishing Group Ltd.



Fig.1 ▶

Sir Benjamin William Rycroft, OBE, MD, FRCS (1902-1967)



Fig.2 ▶

Sir Tudor Thomas MD MS FRCS (1893-1976) President of the Ophthalmological society of the UK (1966-1968)

## OF FATHERS AND SONS: ANTONIO SCARPA (1752–1832)

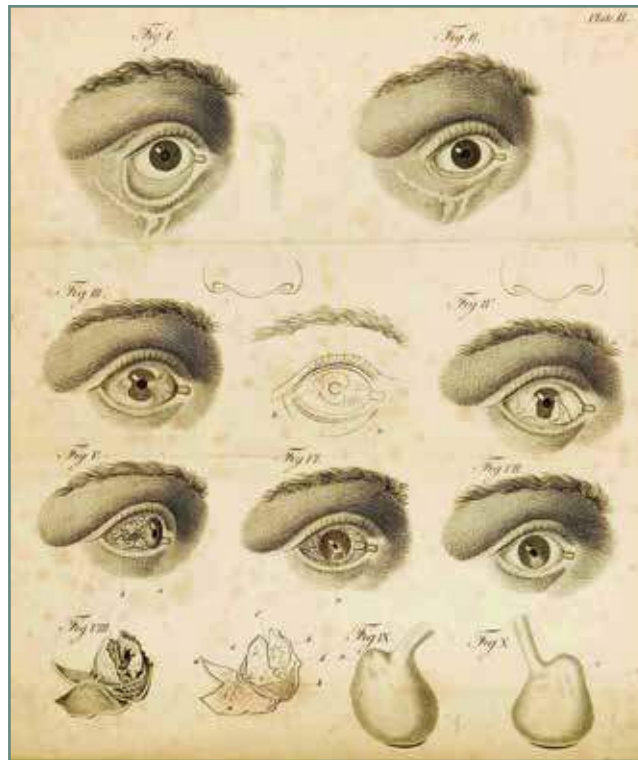

Science in general and Medicine in particular have many individuals who have been described as the Father of something or the other. Some of their students or disciples, "Sons", have gone on to achieve sufficient greatness to attract the title in their own right. Antonio Scarpa (fig.1) was one such individual, described as the Father of Italian Ophthalmology, though he himself was not an ophthalmologist. Antonio Scarpa was one of the greatest anatomists and surgeons of all time. He studied at Padua under Giovanni Battista Morgagni (1682-1771) the founder of pathological anatomy and was greatly influenced by him. The illustration above comes from a book which is considered a classic in the history of ophthalmology. It was the first edition of James Briggs' English translation of Antonio Scarpa's *Practical Observations on the Principal Diseases of the Eye* (1806). The first book was published in Italian in 1801 and was described by Garrison and Morton thus: "This beautifully illustrated work was the first textbook to be published in the Italian language. Its author has been called the Father

of Italian ophthalmology". Duke-Elder states that it marked "the highest culmination of the Galenic tradition of ophthalmic pathology" and in which "all inflammations of the eye were merely *ophthalmias*" without specific differentiation". The book, which was a standard work for several decades, passed through five editions in Italian and was translated into English, German, Dutch with the final sixth edition in French in 1839. In C Wilbur Rucker's book *The History of the Ophthalmoscope* the author puts forward a number of citations from the ophthalmic literature under the subject of Luminosity in Abnormal Eyes. One of them was by Scarpa who described a light-coloured spot at the bottom of the eye that was visible through the pupil in certain cases of amaurosis "...in which the bottom of the eye, independently of the opacity of the crystalline lens, has an unusual paleness, similar to horn, sometimes inclining to green, reflected from the retina as if from a mirror". He did not state under what type of illumination it was visible nor if he used lenses or mirrors to view it.

James Briggs, who so ably translated Scarpa's original book into English, was a member of the College of Surgeons and assistant-surgeon to the Public Dispensary. Scarpa received his MD at the age of 18 and 2 years later became Professor of anatomy and theoretical surgery at Modena from 1772 to 1783. He was professor of anatomy at Padua from 1783 until 1812 and died there in 1832 at the age of 80. In 1791 he had been elected as a Member of the Royal Society. Scarpa was a skilled draughtsman and was probably the most artistic of all medical men, as the drawing of the anatomy of a head (fig.2) demonstrates. The late Paul Henkind MD describes the drawing at the base of this plate as "one of the triumphs

of anatomical dissection brilliantly rendered so that science and art become one. Scarpa made this illustration to emphasise the anatomical basis for the treatment of lacrimal fistula."

Several structures carry his eponym; Scarpa's ganglion, Scarpa's membrane and Scarpa's triangle being three of them. He made anatomical discoveries in the internal ear and vestibular system as well as studies on aneurysms, congenital club foot in children and hernias. In all of these the drawings were mainly his own.

Reproduced/adapted from Br J Ophthalmol, Of fathers and Sons: Antonio Scarpa (1752-1832), R. Keeler, A.D. Singh, H.S. Dua, 97, 1368, Nov 1 2013 with permission from BMJ Publishing Group Ltd.



Fig.1 ► Antonio Scarpa (1752-1832)



Fig.2 ► Scarpa's anatomy of the human head

## THE AMBLYSCOPE THAT WAS "WORTH" IT



The amblyoscope (above image) is an instrument that was designed to develop the fusion faculty of a young patient with squint. The Worth amblyoscope was first constructed in 1895 by Mr Hawes of AW Hawes, Opticians in Leadenhall Street, London. It consists of two equal halves joined together in the middle by a hinge. Each half has a short tube of 1.5 inches diameter which is joined to a longer one at an angle of  $120^\circ$ . At the end of the tube there is a slide carrier where pairs of slides with complementary images can be mounted (fig.1). The paired objects that are mounted in the slide carrier are simple diagrams pasted on glass or etched on plastic. The arc can be moved to give a convergence of the visual axes of up to  $60^\circ$  or separated to give as much as  $30^\circ$  divergence. The instrument illustrated is mounted on a base but it was more commonly hand-held and sometimes suspended from the ceiling.

In 1906 Dr Nelson Black reported the addition of a vertical movement which became known as the Worth-Black amblyoscope. The vertical deviation of  $20^\circ$  above and  $33^\circ$  below the

horizontal plane was attained with this model. This enabled dealing with vertical squints as well.

A squinting person is made to make the pictures overlap by moving the tubes towards and away from each other, the angle of squint can then be read from the graduated scale. Many paired slides have been produced over the years but there are three basic series, one to stimulate binocular vision such as the bird and the cage. The second series are paired slides with images arranged such that fusion of both is required to produce the complete picture, part of each object being on each slide. The third series consisted of stereoscopic pictures giving the impression of three dimensions. Illumination of the slides was often required and the lamp could be clipped onto the back of the slide carrier. Worth's amblyoscope was the forerunner of the synoptiscope or synoptophore, the first model being designed by William Ettles in 1912 but not made available until 1922/3 (fig.2).

Claud Alley Worth (1869–1936) (fig.3) was born in Lincolnshire. He qualified in 1893 as an MRCS

and 5 years later he became a FRCS. Worth studied under Henry Power and Bowater Vernon at Bart's Hospital. He then joined Moorfields Eye hospital in Holmes Spicer's clinic.

He was elected to the staff in 1906 and became consulting surgeon. His book Squint published in 1903 became a classic and has run into many editions and translated into other languages.

A fuller biography of Claud Worth can be read in the article, Worth's Ivory- Ball test on page 60.

Worth was essentially a pioneer in the treatment of squint and contributed many papers to Transactions of the OSUK. Worth was very successful in examining and dealing with small children. The May 2012 edition of the British

Journal of Ophthalmology featured the Ivory Balls bearing his name that he used to assess the vision of very young children<sup>1</sup>.

The Claud Worth medal is awarded annually by the British and Irish Paediatric ophthalmology and strabismus association for "A lifetime distinction in Paediatric ophthalmology and strabismus" to a distinguished individual in the field. Worth was also an accomplished mariner. He was president of the Little Ship Club and Vice-Commodore of the Royal Cruising Club. His published books on Yacht cruising and Yacht navigation were very popular.

Reproduced/adapted from Br J Ophthalmol, The amblyoscope that was 'Worth' it, R. Keeler, A.D. Singh, H.S. Dua, 97, 1495-1496, Dec 1 2013 with permission from BMJ Publishing Group Ltd.

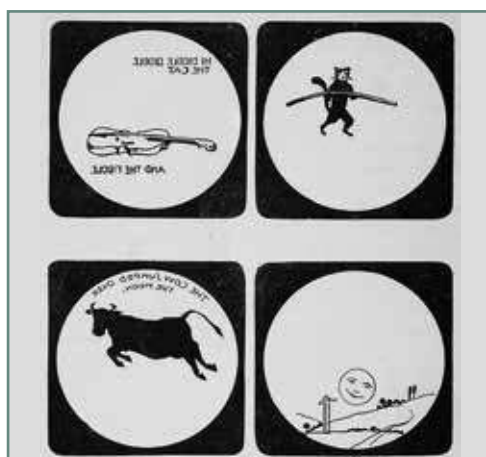

Fig.1 ▶ Images of fusion slides used in the amblyoscope. Each part of the pair of images is presented to one eye. With fusion the images are seen as one "the cat and the fiddle" and "the cow jumped over the moon"



Fig.2 ▶ The first model of the synoptoscope also known as the synoptophore



Fig.3 ▶ Claud Worth (1869–1936)

<sup>1</sup> Keeler R, Singh AD, Dua HS. Testing vision can be testing: Worth's ivory-ball test.

# JOHN VETCH AND HIS TRACHOMA BATTLES

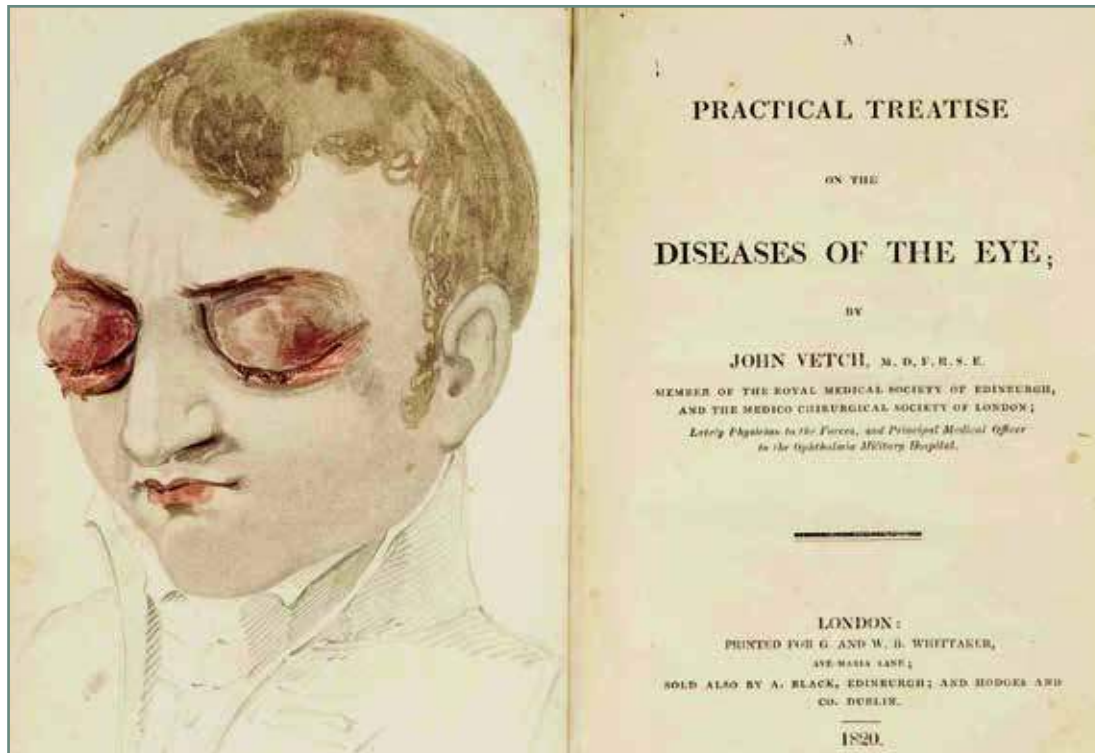

This narration gives a brief account of a British Physician John Vetch (1783-1835) who battled against trachoma largely contracted in the battlefield and had to fight a personal battle in the process.

The word "ophthalmia" is used to describe inflammation of the eye especially of the conjunctiva, and is used interchangeably with the word "ophthalmitis". A book entitled *An Account of the Ophthalmia*, written by John Vetch and published in 1807 (fig.1) established Vetch's reputation as an expert in the ophthalmias, and made him famous. This report is a fundamental part of the history of purulent ocular inflammation. In 1820 he published another book entitled *A Practical Treatise on Diseases of the Eye* (see image above and fig.2). The legend for the colour plate above reads "represents a case of purulent Ophthalmia, in which the external oedema has nearly ceased, and the tarsi are beginning to turn up, by the preponderance acquired by the fleshy state of the palpebral linings." When compared to other "treatises" of the time, this book was modest in

its scope as it mainly covered the ophthalmias.

Vetch was born in East Lothian, Scotland in 1783. He qualified as an MD in Edinburgh in 1804. He served as assistant surgeon in the Light Infantry a year after he graduated, accompanying the troops fighting Napoleon in Egypt. He spent most of his career in the army specialising in the treatment of soldiers afflicted by trachoma (also known as Egyptian ophthalmia), the subject of most of his writings. Having extensively studied British army soldiers with ophthalmia returning from Egypt in 1801 he was able to describe in detail the symptoms and treatment of this disease advocating copious bloodletting as being the most efficacious intervention. He also used copper sulfate with some success. His assertion that trachoma infection is acquired exclusively by the transmission of exudates from the diseased to healthy eyes is considered a milestone in the history of ophthalmology.

Vetch later became Principal Medical Officer at the General Hospital for ophthalmic cases in the army. He went on to become the highest authority in England on the subject of trachoma.

Trachoma was not restricted to soldiers in the army. An epidemic broke out at the Royal Military Asylum, Chelsea in April 1804 which lasted until 1810. The Asylum was opened to provide shelter, care and education for orphans of British soldiers. During this period over 1500 cases of Egyptian ophthalmia were recorded. In 1809 Vetch was one of several physicians called upon to advise on the control and cure of this disease. Although Vetch was fully aware by then of the contagious nature of this disease he did not appear to insist on the use of separate towels by the children. It was only when Staff Surgeon Patrick MacGregor obtained funds from the Board to purchase sufficient towels for each child to have his own, was the epidemic brought under control.

Another Scottish surgeon Arthur Edmonston, earlier in 1801, had also asserted that a contagion was the cause of trachoma but not exclusively. He and others claimed that ophthalmia could be

acquired through the air, dust or even by looking at a diseased person! Up until 1816 some doctors were still clinging to these theories. In 1817 a bitter controversy broke out between Sir William Adams and John Vetch over the remedies for curing trachoma. This controversy was publicised through publication correspondence between the two individuals. Adams was an advocate of strong emetics claiming priority for his discovery. He sought the nation's gratitude to be expressed by a parliamentary grant for the establishment of a specialist hospital. Vetch was able to present incontrovertible facts to deny Adams his demands.

On his return from the army Vetch settled in London and practiced dermatology and for a time was physician at the Infirmary for Skin Diseases as well as at the Asylum for Recovery of Health. He died in 1835 at the young age of 52.

Reproduced/adapted from Br J Ophthalmol, John Vetch and his trachoma battles, R. Keeler, A.D. Singh, H.S. Dua, 98, 4-5, Jan 1 2014 with permission from BMJ Publishing Group Ltd.



Fig.1 ▶ Left, Plate III from the book shows a strangulated eversion of the internal surface of the superior palpebrae. Right, Title page of Vetch's account of Ophthalmia 1807

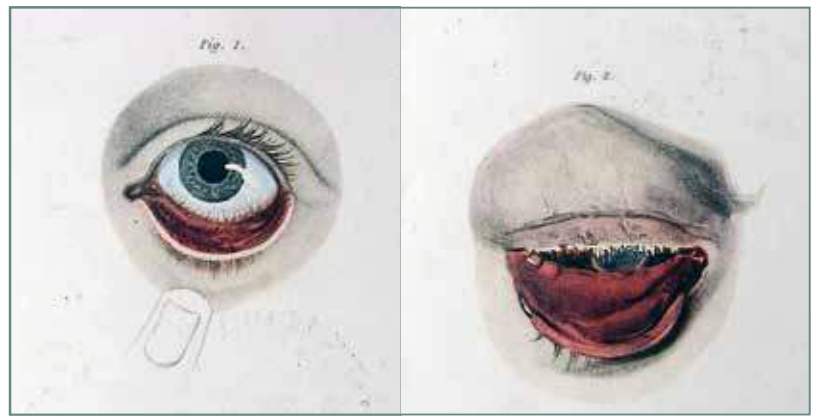
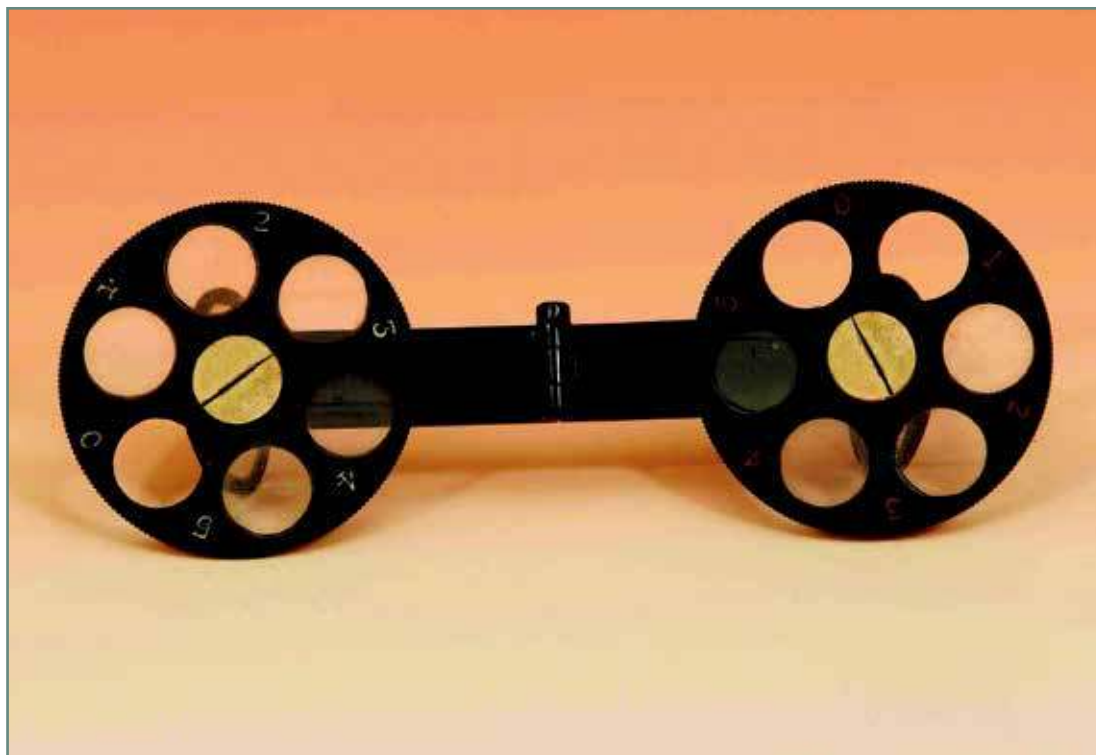

Fig.2 ▶ Plate shows in "fig.1" the state of the lower lid in the convalescent stage of purulent Ophthalmia. In "fig.2" the eversion and paralysis of the lower lid is shown

# THE INSTRUMENTAL NATHANIEL BISHOP HARMAN (1869-1945)



Nathaniel known as Bishop Harman (fig.1) achieved a double first in the Natural Sciences Tripos at Cambridge and went on to train in medicine at the Middlesex Hospital in 1895. He was lecturer and later examiner in anatomy at Caius and King's Colleges, Cambridge. He was made a FRCS in 1898.

He was instrumental in bringing about many innovations and changes during his distinguished career in ophthalmology. He is best known for his fixation forceps, that was designed in 1913 and is still in use. Other instruments that he developed included an aqueous needle, a corneal loupe, a diaphragm test, an eyelid retractor, an ophthalmoscope, a strabismus set of instruments (fig.2) and a refractometer, which is illustrated above. The larger lenses could be overlaid by a swing-over holder with two lenses giving a wide range of lenses for refracting patients. This instrument was essentially a pocket refractor.

He volunteered to serve as a civil surgeon to the Field Force in the South Africa (Boer) War and was decorated with the Queen's Medal with five

clasps. On his return from South Africa he started practicing ophthalmology, working at the Royal London Ophthalmic Hospital (Moorfields) as Chief Clinical Assistant to E. Treacher Collins. In 1909 he was appointed ophthalmic surgeon at the West London Hospital, Hammersmith (founded in 1856 and closed in 1993). He was also appointed ophthalmic surgeon to the Belgrave Hospital for Children in Kennington.

Bishop Harman was a pioneer of reform in the education of children with defective sight. He persuaded the authorities while consultant to the London School Board, (predecessor to the education Department of the London County Council) to institute special classes for these children. These later became special "myope" or "sight saving schools". In addition to designing instruments and equipment he developed school books, emphasising the importance of good lighting. Harman also wrote numerous scientific articles over a broad area of ophthalmology. His books included *The Eyes of our Children* and *Aids to Ophthalmology* in 1919 (the mainstay of knowledge of eye diseases



of many students). In a section on strabismic amblyopia he quoted from Bret Harte's poem The Tale of a Pony.

"Bean pods are noisiest when dry and you always wink with your weakest eye." He wrote poetry himself and in his book of poems, *Today and Other Verses* he included a tribute to Jenner. He also wrote a book on Science and Religion and was in great demand as a speaker in the Unitarian Church.

While serving on the committee for the Causes and Prevention of Blindness, he secured the compulsory notification of ophthalmia neonatorum. Harman had a close connection with the British Medical Association (BMA) over many years and was awarded the BMA Gold Medal in 1931 for his services which included 15 years as Treasurer. He was active in the design

of the new building when the BMA moved to Tavistock Square. He served as Chairman of the Council's Ophthalmic Committee and the Ophthalmic Practitioners Group. In 1929 he established the National Eye Service and was responsible for the BMA backing the NOTB (National Ophthalmic Treatment Board) of which he was Chairman. This was the board that provided free eye examinations for those that could not afford them.

He served in both World Wars, assigning physicians to posts that matched their talents in WWI, and organising medical manpower in WWII. One of a number of discomforts he experienced was lice. Harman wrote about the use of sulphur to rid himself of these parasites.

Reproduced/adapted from Br J Ophthalmol, The Instrumental Nathaniel Bishop Harman (1869-1945), R. Keeler, A.D. Singh, H.S. Dua, 98, 152-153, Feb 1 2014 with permission from BMJ Publishing Group Ltd.



Fig.1 ▶ Nathaniel Bishop Harman (1869-1945)

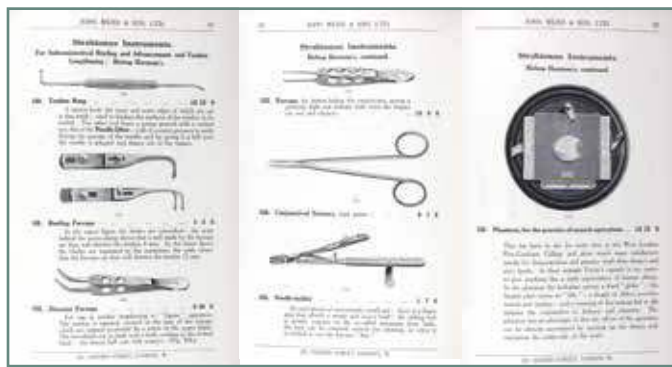
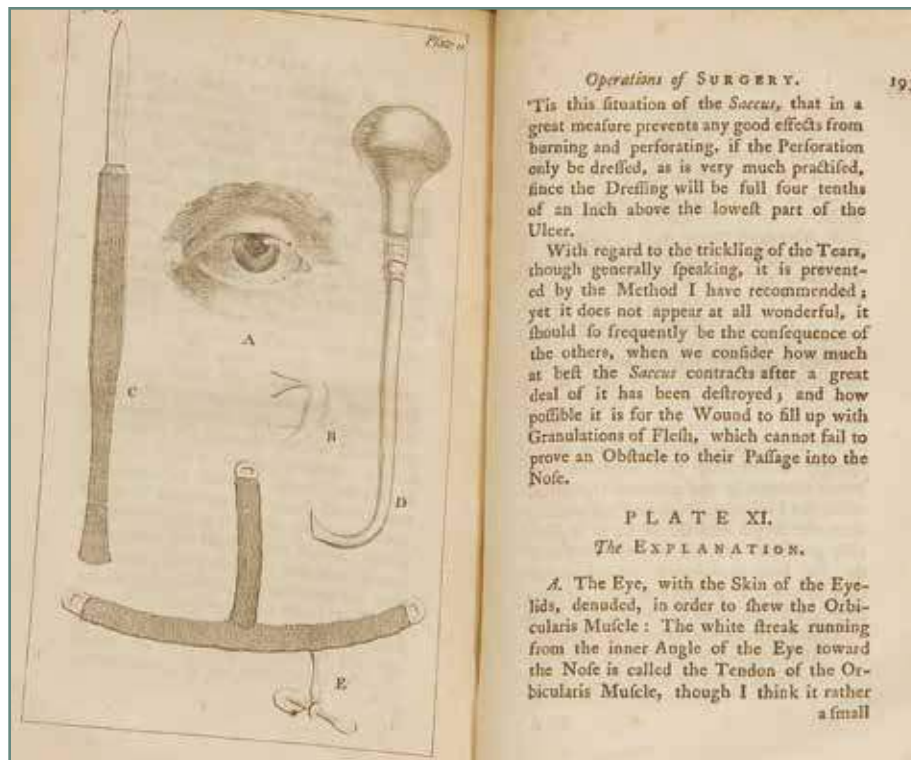

Fig.2 ▶ Bishop Harman's Strabismus Set of instruments from the 1927 catalogue of John Weiss & Son Ltd

# THE SHARPE KNIFE



The history of cataract surgery is punctuated by many great names and many landmark events. In the western world, Jacques Daviel is considered as the early pioneer who performed his first cataract operation in 1747 using a set of instruments. He announced his successful method a few years later at the Royal Academy of Surgery in Paris. A year later, on the 7<sup>th</sup> of April 1753 Samuel Sharpe (fig.1) described his method of opening the cornea with a knife, the only instrument he used, in cataract surgery. That year he read a short paper to The Royal Society on "*A Description of a new Method of opening the Cornea, in order to extract the crystalline Humour*" which was published in the Philosophical Transactions (fig.2). Whilst giving full credit to Jacques Daviel for his invention of the extraction of the cataract he put forward his method of extraction using only a knife. This was faster thereby decreasing pain to the patient as well as preventing the collapse of the eyeball through the special shape of his knife, which he described as "Straight on its flat, somewhat convex on its back, slightly concave on its edge, a little less than an inch long and at its heel about one eighth to one inch wide tapering gradually to a point." Later the same year he

read another paper before The Royal Society "*A second account of the new method of opening the cornea for taking away the cataract*". In this he reported on a number of successful cases using his new knife.

Samuel Sharpe was born in Jamaica, his precise birth date is unknown but was around 1700. Details of his early years, like his birth date are unknown but he appears to have been well educated, being familiar with both the French and Italian languages. In March 1724 he was apprenticed to the greatest surgeon of the time, William Cheselden (1688-1752) of St Thomas' Hospital, to whom his father was obliged to pay £300. With his indentures he was bound to the surgeon for 7-9 years giving his solemn oath of loyalty and obedience and in return he was provided lodging, meat, drink and apparels. The most important benefit of all was to be his introduction to the mysteries and knowledge of the craft of surgery. Sharpe attended Cheselden's famous anatomical lectures and soon became his highly thought-of assistant.

Cheselden introduced Sharpe to Sauveur-Francois Morand of Paris, one of France's outstanding surgeons. Sharpe went to Paris

to study under Morand and later became a member of the Royal Academy of Surgeons of Paris. Although he first met Voltaire (whose real name was Francois Marie Arouet) in London in 1726-1729 he became his frequent guest in Paris.

In 1731 Sharpe was admitted as a "freeman" of the Barber-Surgeon Company. He successfully demonstrated his high proficiency and was granted a "grand diploma" the following year. This meant that he could be called Master in Surgery and Anatomy and could practice anywhere.

Sharpe helped in the preparation of the plates for Cheselden's famous *Osteographia* published in 1733. In 1749 Sharpe became a Fellow of the select body of savants called the Royal Society. Influenced by Cheselden, Sharpe became a surgeon at Guy's Hospital London, close to St Thomas' where he stayed until 1757.

Sharpe's major publications included the "*A Treatise on the Operations of Surgery... (1739)*" of which further nine editions were published in English with one in French (1741) and another in Spanish (1773). In this book there were three short chapters on ophthalmic operations including one on couching the cataract although by the sixth edition he also referred to extraction of the lens by Jacques Daviel and his own method for this cataract operation. In this book there is a chapter "Of cutting the Iris" and one on his operation "Of the Fistula Lachrymalis". The illustration of the instruments he used in this operation is shown at the top of this article. In this image (A) depicts the eye with

the two black spots indicating the orifices of the lachrymal channels; (B) the exact dimension of the lachrymal channels and lachrymal bag; (C) a small incision knife, more handy than a larger one for opening the lachrymal bag; (D) the perforator to destroy the Os Unguis if necessary and (E) a pliable plate attached to the forehead and containing a covered button at the end of a screw to be placed on the Saccus Lachrymalis to provide pressure on the lachrymal bag. In 1750 he published "*A Critical Enquiry into the present state of Surgery.*" Four editions in English and several in foreign languages including French, Spanish, German and Italian followed. He also constituted a course of anatomical lectures to which were added surgical operations. In 1746 due to pressure on his time he resigned his lectures to William Hunter who was then a surgeon. In due course these lectures became the nucleus of the celebrated school of medicine called the "Great Windmill Street School", which was the foundation of modern medical teaching.

Sharpe was greatly in demand and his practice immediately had grown into a large and lucrative one. As a result of the pressure from his large practice and poor health related to asthma, he resigned from Guy's in 1757 but continued to practice until 1765. He died in 1778 having lived to an advanced age of nearly eighty. Sharpe was highly regarded as a surgeon and perhaps was one of England's greatest.

Reproduced/adapted from Br J Ophthalmol, The Sharpe Knife, R. Keeler, A.D. Singh, H.S. Dua, 98, 290-291, Mar 1 2014 with permission from BMJ Publishing Group Ltd.



Fig.1 ▶ *Portrait of Samuel Sharpe (1700-1778) a Legitimate Surgeon and Anatomist Wellcome Library, London*



Fig.2 ▶ *Sharpe's cataract knife. Phil. Tr., Lond., 1753 with enlargement superimposed on right*

# EYE, MAGNETISM AND MAGNETS



Mankind has always been familiar with the magnetism or drawing power of the eyes. Eye contact between mother and child is a strong force in bonding between the two. Eye contact is also the initial signal of attraction between two individuals, triggering special emotions especially if the attraction is mutual. Paramhansa Yogananda describes magnetism, which originates in the "Infinite Spirit", as the power by which one draws things to oneself like the right partner, friends, business associates and others. "Each human being is a medium through which God's magnetism flows. "All parts of the body that come in pairs" such as eyes, ears, hands "form magnets". "Soul magnetism is expressed through the eyes, weakly or strongly, depending on one's spiritual development. Some highly developed people are able to spiritualise or heal others solely by the magnetism of their eyes".

Magnetism transcends from the spiritual to the physical. Iron is an essential element for most living animals and iron compounds abound in Nature. Magnetite, an oxide of iron is the most magnetic mineral on Earth. The ability of naturally occurring pieces of "rock", termed "lodestone" to attract iron particles "magnetism" was known to ancient Man. Crystals of magnetite are distributed extensively in cells and in some species they

enable "magnetoreception", a special sense with which the organism is able to be aware of the Earth's magnetic field and use it to navigate across the globe. Biomagnetism is also manifest in other ways. The front of the eye is electropositive compared to the back. The current that flows from front to back can create a magnetic field around the eye ball which in turn could influence the behaviour of cells. Various "lines" formed by the deposition of iron compounds on the corneal surface have been described - Hudson Stahl line, Stocker's line, Ferry's line, Fliescher ring and other un-named deposits that are associated with angles on the corneal surface created by scars and laser refractive surgery. The vortex or whorl pattern formed by corneal epithelial cells..."hurricane keratopathy" has been attributed to the effect of the electromagnetic field of the eyeball on migrating epithelial cells that may contain magnetite.

It is not surprising therefore that magnets have had a role to play in medicine. There are many reports on the use of magnets to heal tissue like bone and treat disease.

Lodestone was used in India before the Christian era. The first mention of the removal of a foreign body from the eye by magnetic attraction

is attributed to the physician Hieronymus Brunschwyck of Strasburg in 1497. He removed iron filings which had hit the surface of the eye of a patient by placing lodestone against the open lids. Various attempts were made to extract metal foreign bodies from within the eye in the second half of the 19<sup>th</sup> century with more powerful magnets. The first person to insert a magnetic probe within the eye was Dr W A MacKeown (1844-1924) of Belfast. He successfully removed a foreign body from within the vitreous in 1874 by using a long slender terminal in contact with the foreign body. The instrument illustrated above is a magnetic device designed in 1881 by the ophthalmologist Simeon Snell (fig.1). The magnet was designed to be used for the removal of ferrous metal fragments near to or on the surface of the eye. This hand held instrument contrasts with the much larger "giant magnets".

It was Julius Hirschberg (1843-1925), the incomparable ophthalmic historian who, in 1879, was the first to introduce an electromagnet into ophthalmic practice. Amongst his 109 published works including the monumental History of Ophthalmology volumes there are two classical monographs (1885-1899) on operations with his electromagnet which for the first time produced a more powerful "pull" on a foreign body. Snell's instrument is very similar to Hirschberg's with the same wide choice of terminals. The strength of a magnet, measured in Gauss, is determined by the shape and length of the terminal. The blunter the end the stronger the magnetic pull. For the extraction of foreign bodies in the eye a blunt end to the magnet limited the ability to place it close to the site where the metal particle is lodged in the eye. Although longer slender terminals were far less powerful they were more practical. For the most efficient extraction the terminal was placed

as close as possible, if not in contact with the tissue in front of the foreign body.

Simeon Snell was born in Launceston, Cornwall in 1851. He studied medicine in Leeds and then moved to Guy's Hospital in London before spending time at The Royal London Ophthalmic Hospital (Moorfields). He achieved his MRCS in 1872. He then moved to Sheffield where he set up practice and became the first ophthalmologist at the Royal Infirmary in 1879, a position he held for the rest of his career. Sheffield was an industrial city and because of the frequency of eye injuries and foreign bodies in the eye Snell became an authority on operations with the magnet. He also became an expert on the prevention of occupational diseases. In 1892 he was made a Fellow of the Royal College of Surgeons of Edinburgh (FRCS Ed.). He founded the Medical Faculty in Sheffield and became its first Professor of Ophthalmology there.

Like Hirschberg he wrote a monograph (1883) entitled *The Electro magnet and its employment in ophthalmic surgery*. He gave a full description of his instrument in this monograph. Snell wrote on a variety of subjects but mostly on the effects of industry on the eye. Included in his writings are articles on Miner's nystagmus 1884 (he frequently went down the mines to get first hand experience), Glass blower's cataract 1907 and School life and Eye sight. Snell's crowning achievement was being elected President of the British Medical Association, the first ophthalmologist to receive this honour (fig.2). It was in this capacity he received the prestigious award of the Middlemore Prize for his contribution to Ophthalmology.

Reproduced/adapted from Br J Ophthalmol, Eye, magnetism and magnets, R. Keeler, A.D. Singh, H.S. Dua, 98, 425-426, Apr 1 2014 with permission from BMJ Publishing Group Ltd.

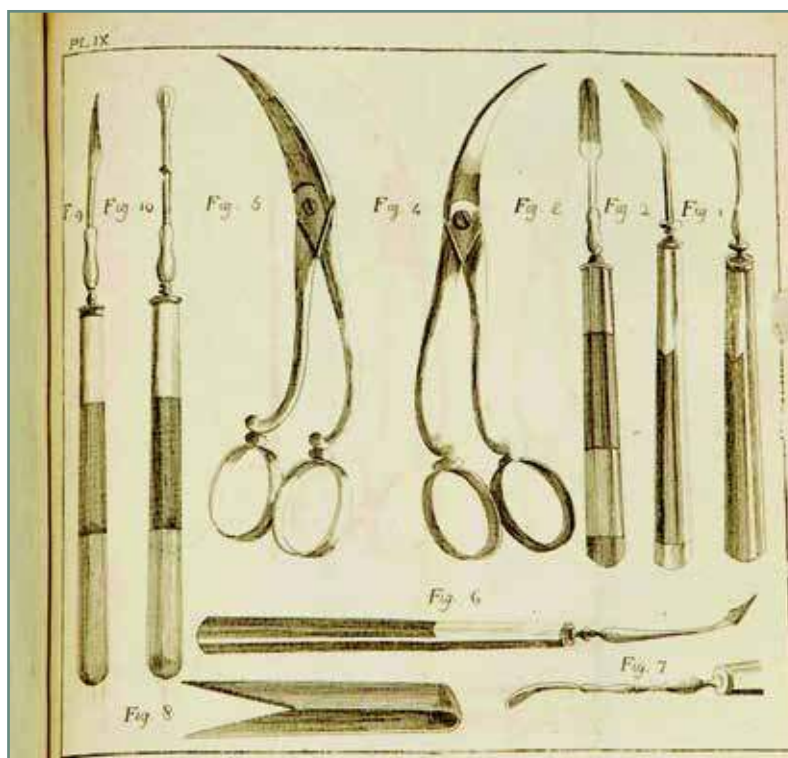

Fig.1 ▶ Simeon Snell (1851–1909)



Fig.2 ▶ Simeon Snell hosting, as President of the BMA, a luncheon at the Royal Infirmary, Sheffield, for visiting ophthalmic surgeons in July 1908. On his left is J Marshall and E Fuchs and on his right H Swanzy and D Argyll Robertson

## GUILLAUME PELLIER DE QUENGSY: A BOLD EYE SURGEON



The subject of this article is the two volume book of Pellier de Quengsy's "*Course of Eye Operations...*" It was the first monograph in the world's literature devoted exclusively to eye surgery. Guillaume Pellier de Quengsy's father, Jean-Henri, was a master of surgery and city physician in Bar-le-Duc and Metz. He had been a pupil of Jacques Daviel. Pellier learned ophthalmology from his father and regarded it as the most difficult part of surgery. He dedicated his whole life to this speciality. Pellier later dropped the "De Quengsy" part of his name probably because of the revolution in an attempt to be one of the people.

Pellier's first book in 1783 was on diseases of the eye and adjacent structures and how to cure them. In it he introduced a new method of the extraction of the cataract using an instrument of his own invention, the ophthalmotome. His major two volume work (fig.1) entitled "*Precis ou cours d'operations sur les yeux...*" (Abstract or course of eye operations.), which was completed in 1789-90 is profusely illustrated with 300 exquisite copper engravings on 33 folding plates, a few of which are reproduced here (fig.2). The first volume deals in great length with

his and other surgeons' methods for the cataract operation. He popularised Jacques Daviel's cataract extraction operation first performed in 1747 arguing against couching which was still prevalent. The image above illustrates the instruments used in Daviel's method of cataract extraction as described by Pellier in his book.

Pellier became famous in Montpellier and throughout France for his cataract operation. He used his ophthalmotome knife (fig.3) with which he was able to perform cataract extraction with one swift manoeuvre. The pointed, sickle-shaped knife with the cutting edge on the curved side incised the eye in a vertical direction and continued this movement with the point opening the lens capsule. The knife was then pushed out of the eye on the other side and drawn downwards completing a large section of two thirds of the eye. Pressure was then exerted by the fingers to express the lens. After the incision the knife was withdrawn into the hollow handle by pressing a knob which at the same time released a spoon used to remove lens fragments and replace the iris. No sutures were used and the whole operation was completed in one minute.

Perhaps of greatest interest, especially to corneal surgeons, is Pellier's idea of how to treat scarred corneas surgically. He proposed an artificial cornea made of glass as a substitute for the patient's scarred cornea (fig.4). The spherical glass disc was supported by a silver ring around which was attached a grooved skirt. The artificial eye with groove was fitted over the thickness of the sclera and was then sutured to the eye. Pellier who described in great detail how the operation should be carried out recommended that it should be done on a sunny day! He did not perform this operation himself until years later but left it to more junior surgeons including his brother. All attempts failed. It was to take another century and a half before a more successful attempt at a keratoprosthesis was made.

The second volume, which contains all the illustrations referred to in the text, includes diseases of the vitreous, removal of the eye and a discussion of the lid and lacrimal sac. Pellier de Quengsy was a teacher of the first rank and an innovator with many original ideas. Between 1772 and 1776 he travelled extensively to 20 towns in France lecturing and operating. He finally settled to practice in Montpellier where he remained until his death in 1835 at the age of 84. He is regarded as one of most clever and brilliant practitioners of the 18<sup>th</sup> century.

Reproduced/adapted from Br J Ophthalmol, Guillaume Pellier de Quengsy: a bold eye surgeon, R. Keeler, A.D. Singh, H.S. Dua, 98, 576-578, May 1 2014 with permission from BMJ Publishing Group Ltd.

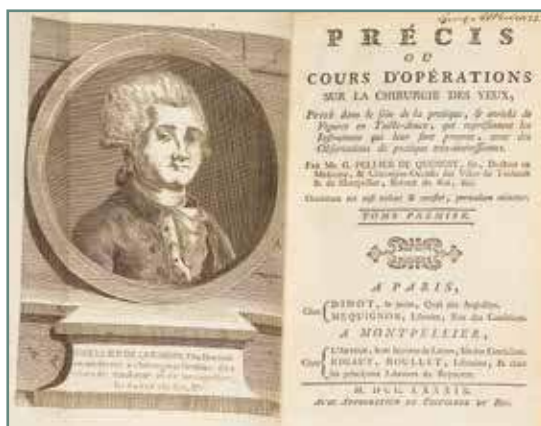

Fig.1 ▶ This Plate shows the title page of G. PELLIER DE QUENGSY's two volume book, *Precis ou Cours d'opérations sur la Chirurgie des Yeux*, with a portrait of the author on the opposite page



Fig.2 ▶ Reproduction of Plate VI from the book wherein Pellier describes twenty three different appearances of a cataract



Fig.3 ▶ Reproduction of Plate VIII of Pellier's book depicting a drawing of Pellier's ophthalmotome which he designed to perform cataract extraction in just over a minute. The knife can be seen in fig. 1 with the same handle being used to contain a spoon as in fig. 2. On contracting the knife the spoon appeared. Pellier claimed that he only used this one instrument for his operation compared to other surgeons including Daviel who used different instruments for different steps of the operation

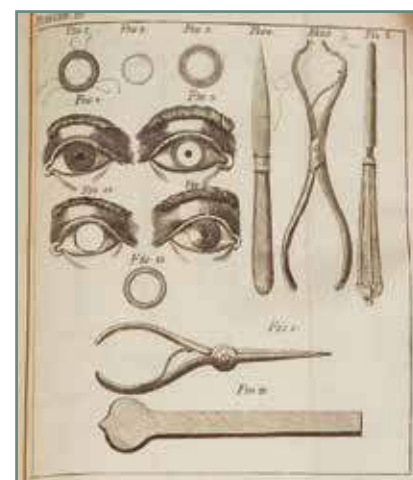

Fig.4 ▶ Reproduction of Plate IV of Pellier's book, which illustrates the step by step procedure, with the instruments used, of his proposed method of replacing a scarred cornea with a glass one













## EDITION

Edited by:

Laboratoires Théa

12 Rue Louis Blériot - ZI du Brézet

63017 Clermont-Ferrand cedex 2 - France

Tel. +33 (0)4 73 98 14 36 - Fax +33 (0)4 73 98 14 38

[www.laboratoires-thea.com](http://www.laboratoires-thea.com)

*Théa Medical Library Collection*



Laboratoires Théa  
12 Rue Louis Blériot - ZI du Brézet  
63017 Clermont-Ferrand cedex 2 - France  
Tel. +33 (0)4 73 98 14 36 - Fax +33 (0)4 73 98 14 38  
[www.laboratoires-thea.com](http://www.laboratoires-thea.com)